

USER MANUEL HGD 02

Foreword	2
Introduction	3
Technical Details	4
Normsand Certificates	6
Definition and Warning Stickers on the Refrigerator	7
Assembling and Environmental Situations	10
Connecting Refrigerators	11
Asemmbling the Endwalls	16-19
Assembling the Lower Decor and the Kickplate	17
Assembling the Shelf Bracket and Shelf	24
Changing the Door Direction	25
Illumination	28
Electricity Connections	29
Heat Control	30
Loading the Refrigerator	31
Defrost and Drainage	32
Valve Location	35
Care, Cleaning and Technical Service	36
Recycling	38
Spare Parts	39
Electrical Diagrams	42

1. Foreword

This guide is prepared for the HGD refrigerator. The details below are examined in general.

- How the refrigerator will be used
- Technical Details
- Installation and Assembling
- Infos and suggestions for the users
- Care operations

Producer company does not have any responsibilities about the situations below.

- Wrong usage of the refrigerator
- Wrong assembling
- Electrical Effects
- Not doing the periodical cares
- Changes of Operation
- Not using the original spare parts
- Ignoring the given infos

P.S. : Applications about electricity are dangerous for your life. Anyone who uses the refrigerator must read this guide.

1. Introduction

Hgd 02Baltic is a vertical, half front-doored, with the well section multi-shelfed cooler refrigerator. Its condensing unit is designed as remote. With its wide display area and loading capacity, it is suitable for usage of stores and larger stores. Foodstuffs such as frozen meat, fish and ice-cream can be displayed in the cabinet. The cabinet has a defrost-type resistance.

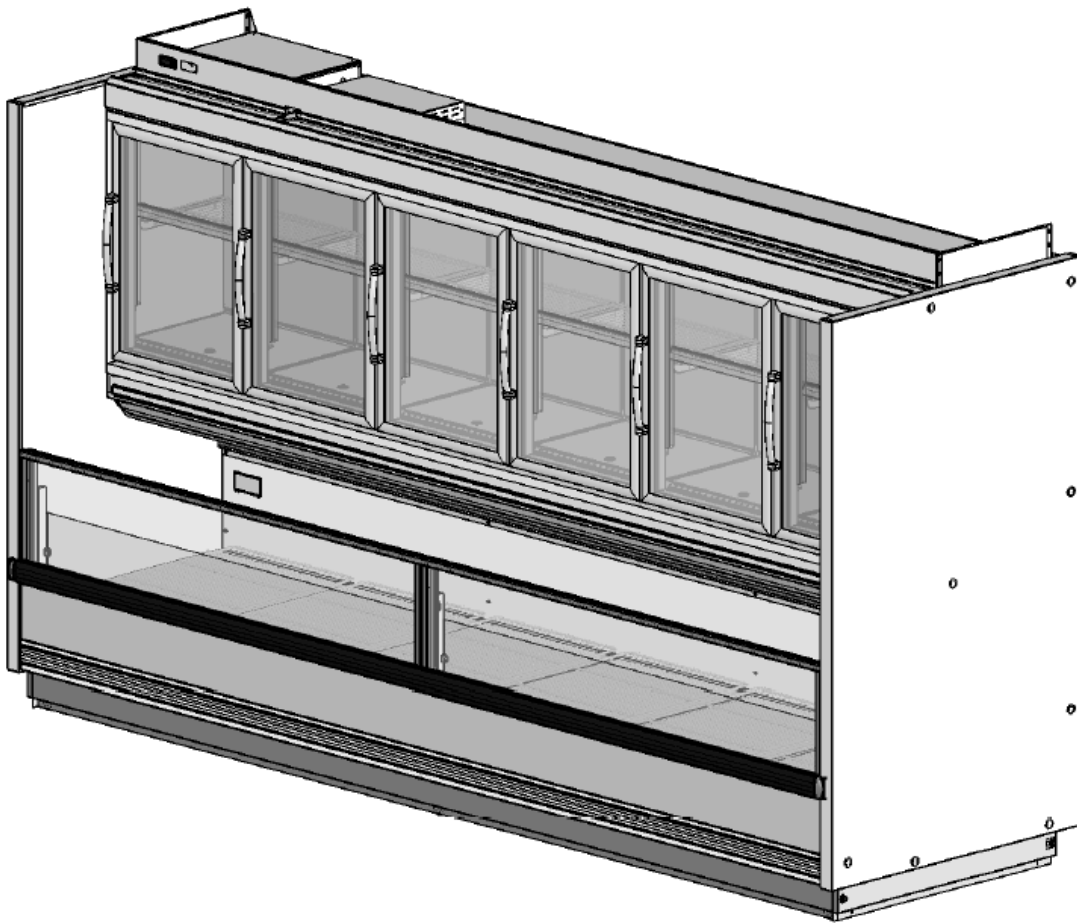

2. Technical details

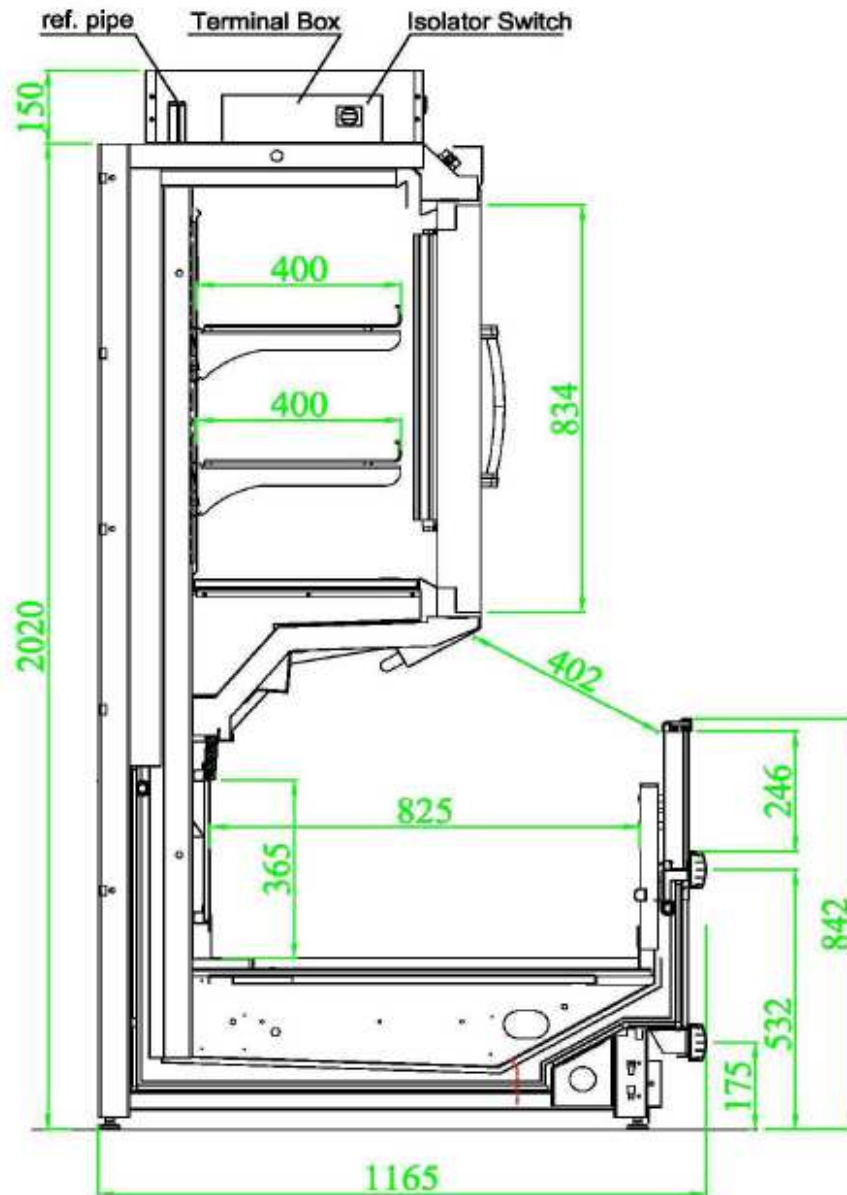

	TECHNICAL DOCUMENTATION	CHAPTER REVISION STATUS					
		ORD.	DATE	CHANGE ORDER	ORD.	DATE	CHANGE ORDER
PRODUCT	HGD-02	A			D		
DATE of 1st ISSUE	18.10.2010	B			E		
ORDER	ULAS GÜDÜCÜ	C			F		

 TECHNICAL DATA SHEET - HGD-02
--

TECHNICAL DETAILS	2500	3750
--------------------------	-------------	-------------

Refrigeration Load		
Case Temp (°C)	-21/-23	
Evap Temp (°C)	-32	
Duty (kW)	2,25	3,37
Expansion Valve (R404)	TES2 Or. AKV 10-4	TES2 Or. AKV 10-5
Pipe Size - Suction	19 mm	22 mm
Pipe Size - Liquid	3/8"	
Pipe Size - Drain	40 mm	
Cubic Capacity (dm ³)	1550	2325
TDA (prEN ISO 23953-2)	2,04	3,05

Defrost Details	
Defrost Type	Electric
Duration (minutes)	3 x 45
Termination	Temp (+8 C)

Heaters		
Evaporator (Coil)	4 x 800W	4 x 1200W
Frame (Schott Termofrost)	330 W	509 W
Doors (Schott Termofrost)	4 x 66W	6 x 66W
Front Glass	124W	2 x 94W
Side Glass	-	-
End Walls	-	-
Body	3 x 50W	3 x 75W
Water Drain	16W	16W
Air Return	200W	2 x 150W
Air Intake	-	-

Electrical / Fans			
Supply	230 V / 50 Hz		
Lighting (T5)	on frame	5 x 14W	7 x 14W
	on well	2 x 28W	3 x 28W
Evaporator Fans "1700 RPM"	2 x 7W (AO 154mm/28°)	3 x 7W (AO 154mm/28°)	
	2 x 7W (A 154mm/22°)	3 x 7W (A 154mm/22°)	

Design Conditions					
Temp (°C)	25	Humidity (%)	60	Cross Draft Air Speed (m/s)	0,2

	TECHNICAL DOCUMENTATION	CHAPTER REVISION STATUS					
		ORD.	DATE	CHANGE ORDER	ORD.	DATE	CHANGE ORDER
PRODUCT	HGD-02	A			D		
DATE of 1st ISSUE	13.10.2010	B			E		
ORDER	ULAS GÜDÜCÜ	C			F		

4. Norms and Certificates

The approved certificates of norms and refrigerators that are using as reference;
EN 60204-1; EN 60439-1; EN 60439-2

ENVIRONMENTAL CLIMATIC ATMOSPHERE (EN 441-4)

This refrigerator is tested as to atmosphere heat class 3.

Klimatik ortam	Kuru hava sıcaklığı	Bağıl nem	Çiğ noktası
1	16°C	%80	12°C
2	22°C	%65	15°C
3	25°C	%60	17°C
4	30°C	%55	20°C
5	40°C	%40	24°C
6	27°C	%70	21°C

The directives that the refrigerator fits **EEC 73/23** , **EEC 98/37**

5. Warning and definition stickers on the refrigerator

YÜKSEK GERİLİM ETİKETİ



ÜRÜN TANIM ETİKETİ

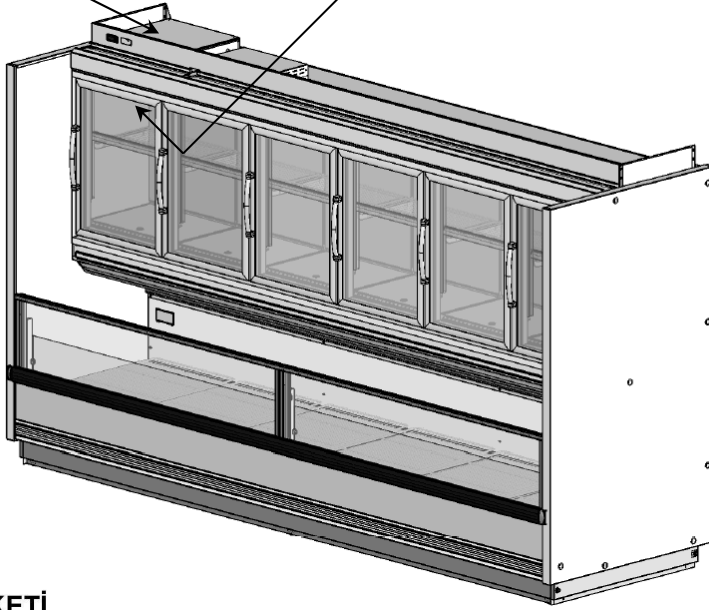
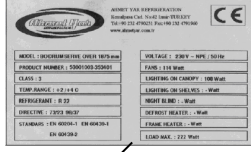

BASINÇ ETİKETİ

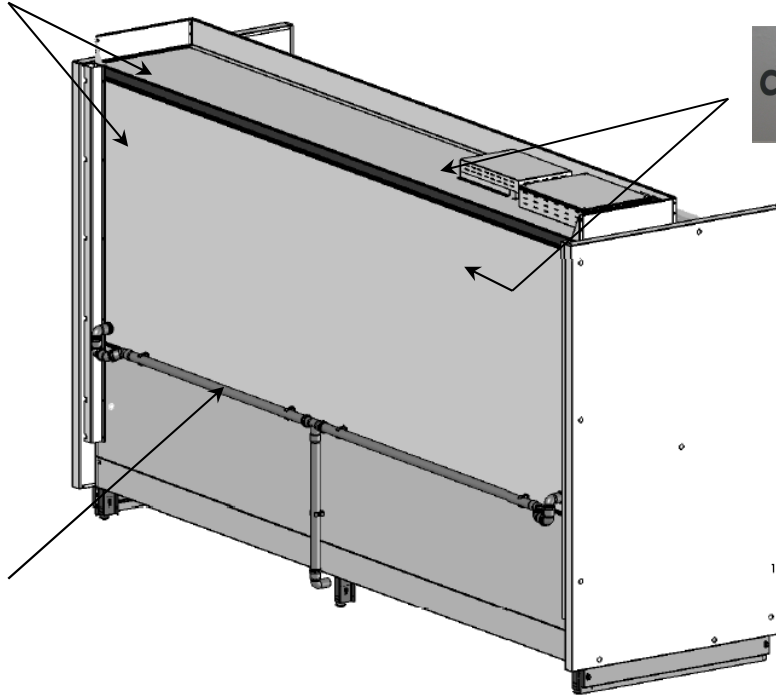

C - PENTANE

TAŞIMA ETİKETİ

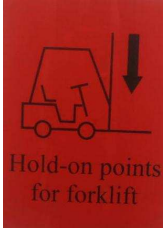

High Voltage Sticker

High voltage sticker is located on the electricity box.



Product Definition Sticker

Product definition sticker is located inside the refrigerator on the ceiling and includes all technical properties.

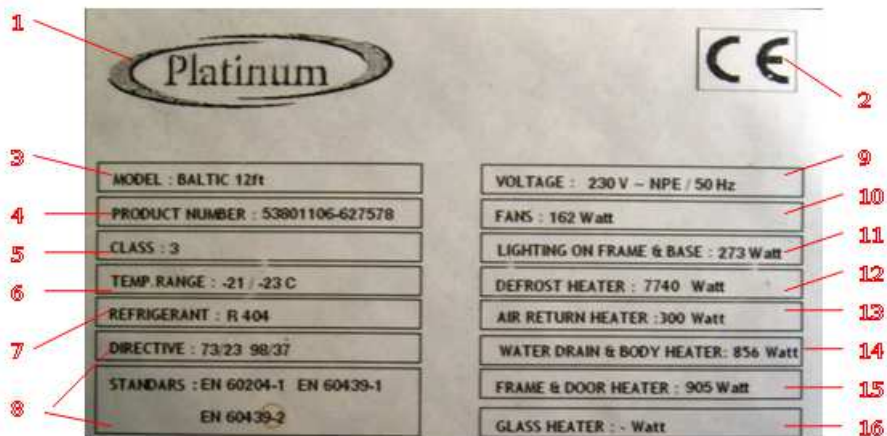

1. Logo and address info of the producer company
2. Product certificates and quality certificates of producer
3. Model of product
4. Serial number of product
5. Air Conditioner class of product
6. Heating limits of product
7. Type of the cooler liquid used in product
8. Approved certificates of product and standart directives
9. Working voltage infos
10. Fan power of evaporater
11. Electricity power of illumination
12. Electricity power of under-shelf illumination
13. Electricity power of night blind
14. Electricity power of defrost resistances
15. Electricity power of total electricity power of frame resistances
16. Total electricity power

Transportation Stickers

There are palettes located on the refrigerator for transportation. Transportations with forklifts or transpalettes are materialized by the assistance of these palettes. There is a sticker behind the refrigerator about the transportation palettes. The sticker must be centered with the forklift handles during the transportation as shown in the diagram below.

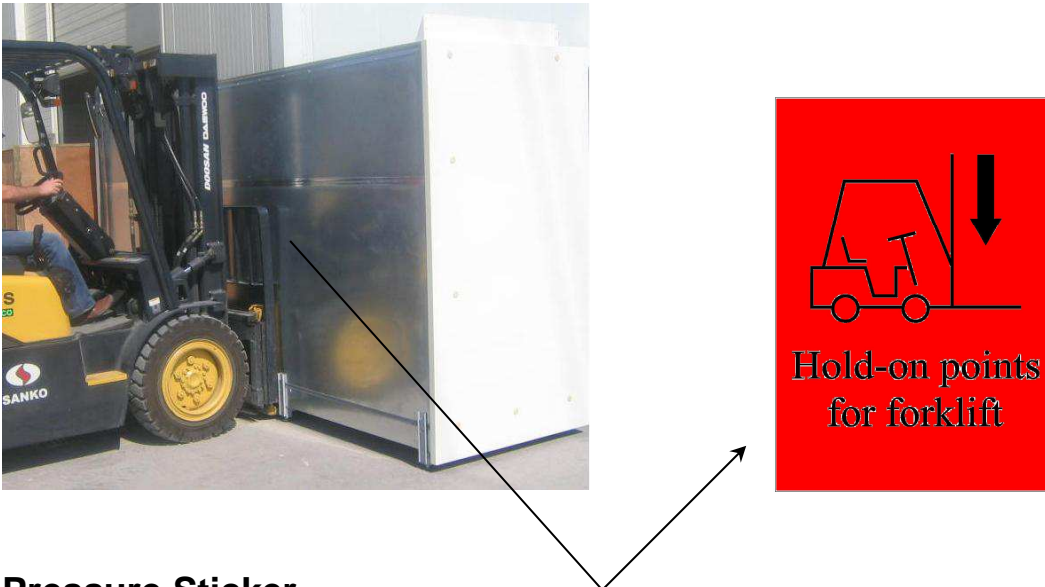

Pressure Sticker

Pressure sticker is located at the exit points of the copper pipes. It is used for determining the quantity of nitrogen.



Pentane Caution sticker

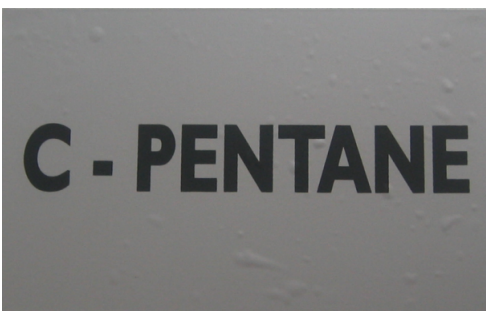

Pentane is a fairly burning*** gas and it forms a explosive mixture with H₂O. Polyurethane urged refrigerator bodies contains pentane. Pentane warning sticker is located at two places. One is at the upper right side behind the refrigerator and the other one is at the upper right part of the refrigerator.

6. Assembling and Environmental Situations

Follow the instructions below for assembling.

The situations that must be paid attention to placing the refrigerators

- Do not leave or assemble the refrigerator at the positions below ;
 - Closer to any explosive gasses
 - Closer to heaters
 - Through the draught

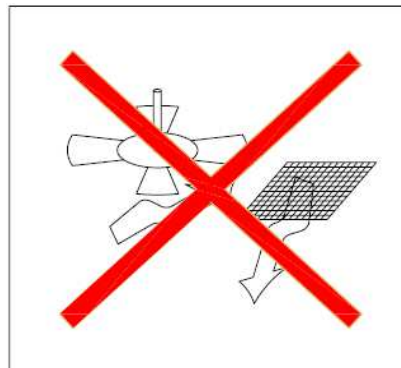
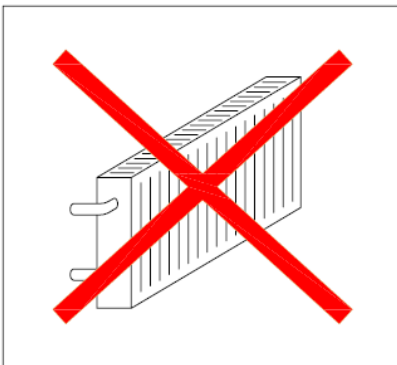
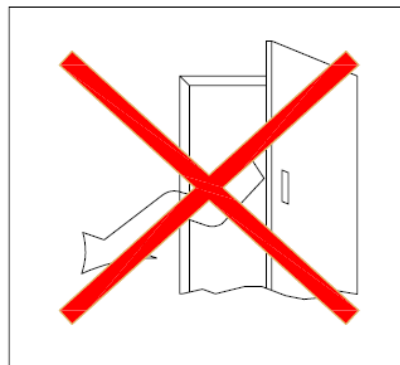
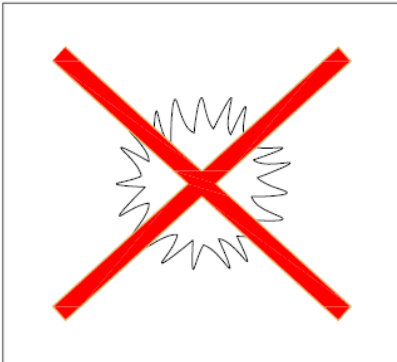

7. Connecting Two Refrigerators

Follow the sequences below for connecting two or more refrigerators.

- Disassemble the endwalls (if exist)
- Place the refrigerators closer to each other
- Disassemble the palette. Level the refrigerators by arranging the heights of cabinet legs. (Diagram 1) Check on the balance by using water ballance*** (Diagram 2). Check the balance of the refrigerator by moving it.

➤ Side Pillar Connection

- Attach the connection equipments to the connection hole which is located near the refrigerator on the base tray pillars. Connection equipments and their locations are shown on the (Diagram 4).



Şekil 1

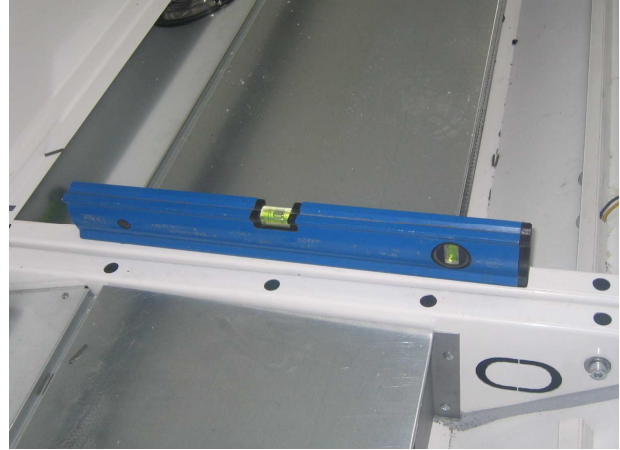

Şekil2



Şekil 3

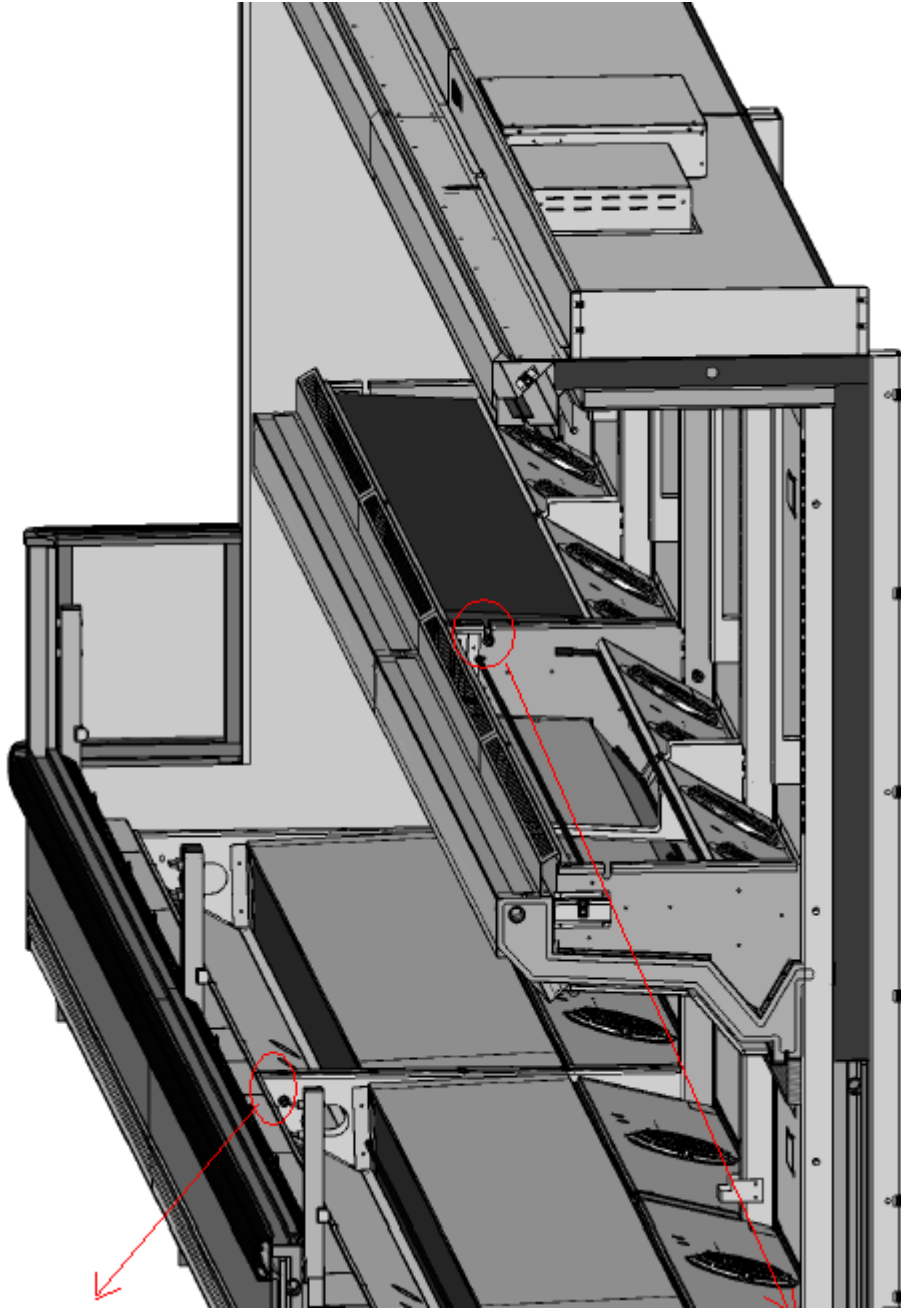

Şekil 4

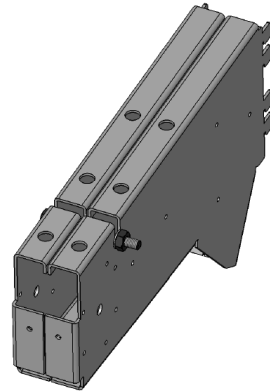
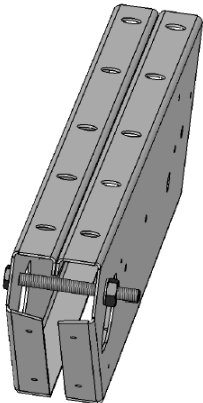

Hgd 02 alt dikme tabanı birleştirme
Kesit ön görünüş;

Hgd 02 orta dikme tabanı birleştirme
Kesit ön görünüş;

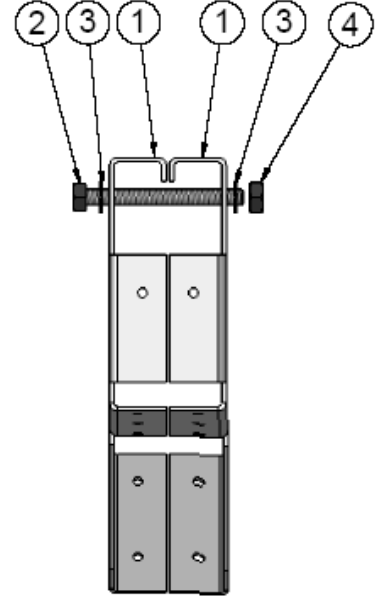
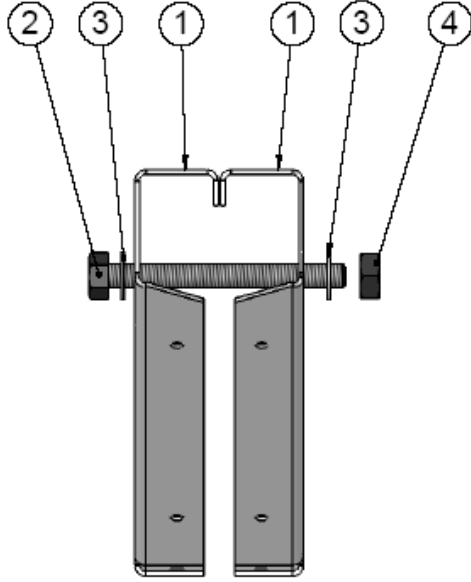

POZ NO	PARCA ADI	ADET
1	Dolap yan dikme tabanı	Ürün üzerinde
2	M8x90 Altı köşe başlı civata	2
3	M8 Rondela	4
4	M8 Somun	2

➤ FRONT BODY AND UPPER PANEL CONNECTIONS

- There are two units of refrigerator connection sheets on the roof of refrigerators and one connection sheet is located on the front lower body of refrigerator. (Diagram 5)
That's why attach the connection bolts to the connection holes which are on the refrigerator connection sheets and then tighten the bolts. (Diagram 7)

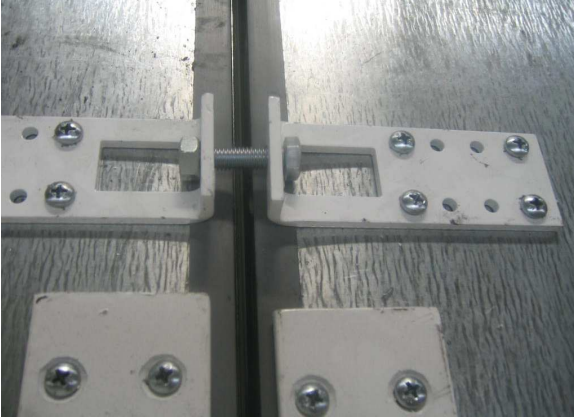

Şekil 5



Şekil 6

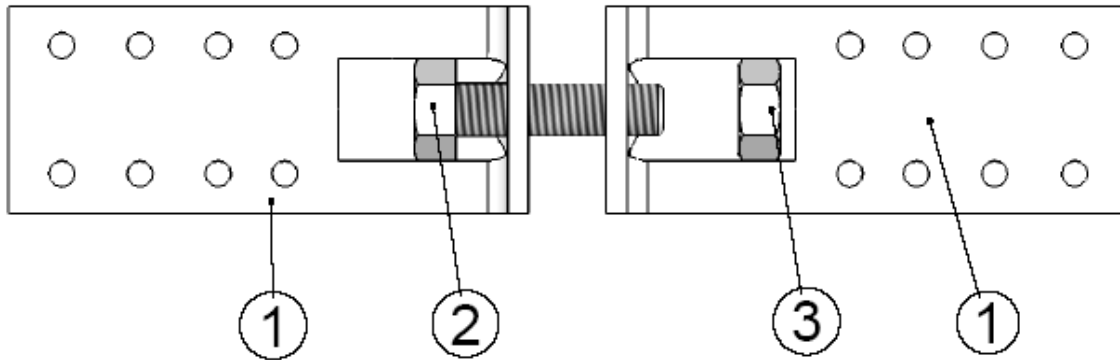

Şekil 7

POZ NO	PARÇA ADI	ADET
1	Dolap birleştirme sacı	5
2	M8x40 6K	5
3	M8 Somun	5

➤ SIDE PILLAR CONNECTIONS

Side pillars must be connected from the two holes with bolts just as shown on the diagram 8.

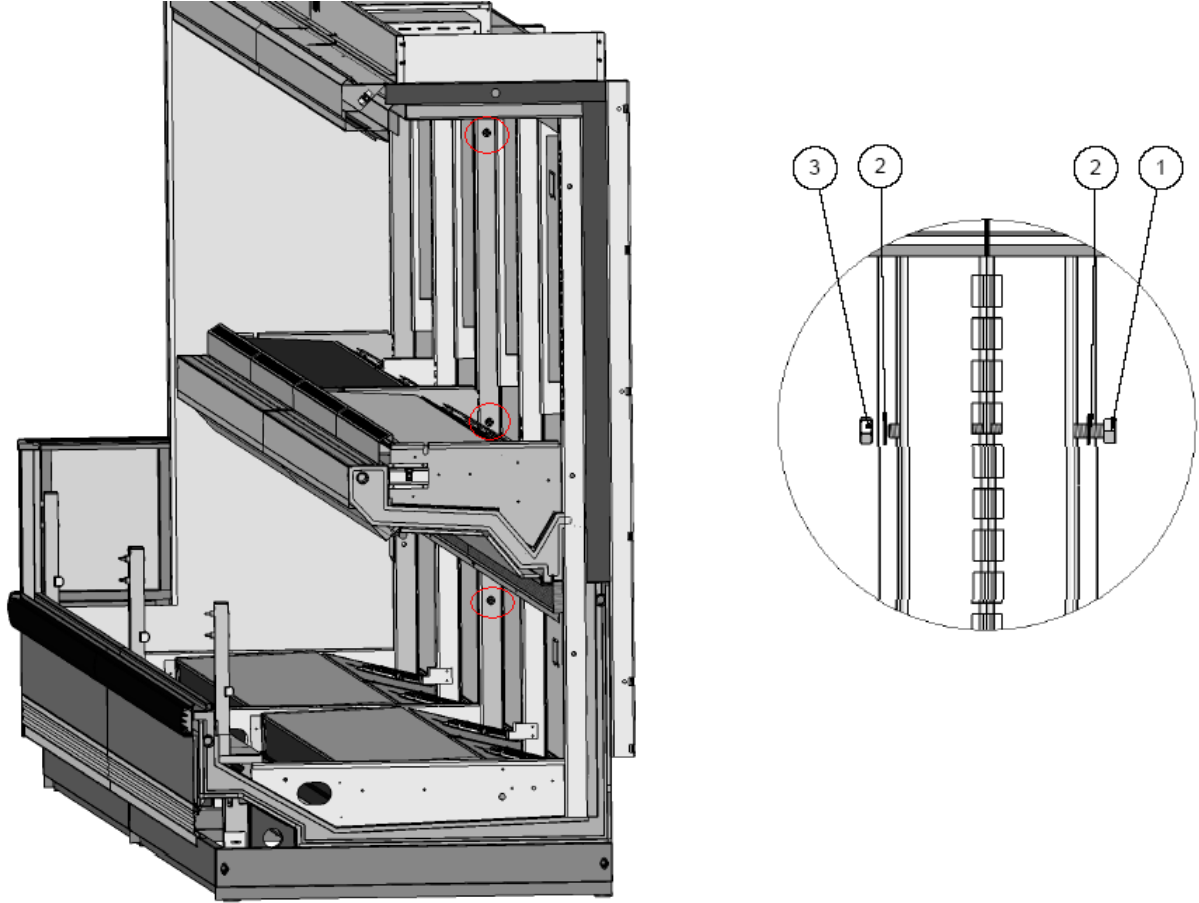

Şekil 8

POZ NO	PARÇA ADI	ADET
1	M8x150 6K Kaplamalı civata	3
2	Pul rondela	6
3	M8 Somun	3



8. Assembling the Endwalls

Before assembling the endwalls, bumper end and decor cap must be assembled to the bumper and decor ends.

➤ Assembling the Lower Decor Aluminiums

Screw the upper aluminium of the lower decor as shown in Diagram 9. Then assemble the decor legs to the holes of the lower aluminium of lower decor with kickplate mace screw and Special M6 Nut.(Diagram 10). After placing this assembly to the channel of upper aluminium of lower decor, screw the lower aluminium of lower decor from its decor legs to the bottom of the body with M6.(Diagram 11).

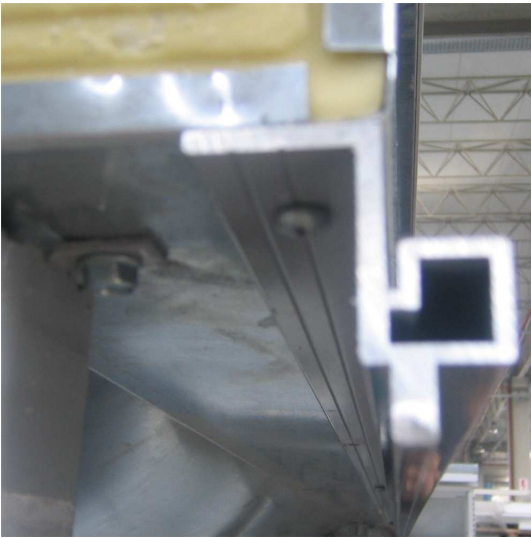

Şekil 9

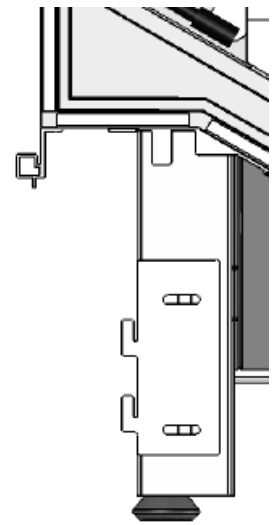

Kesit yan görünüş



Şekil 10



Şekil 11



Kesit yan görünüş

Assemble the lower decor sheet to the bumper holder as shown in Diagram 12.



Şekil 12

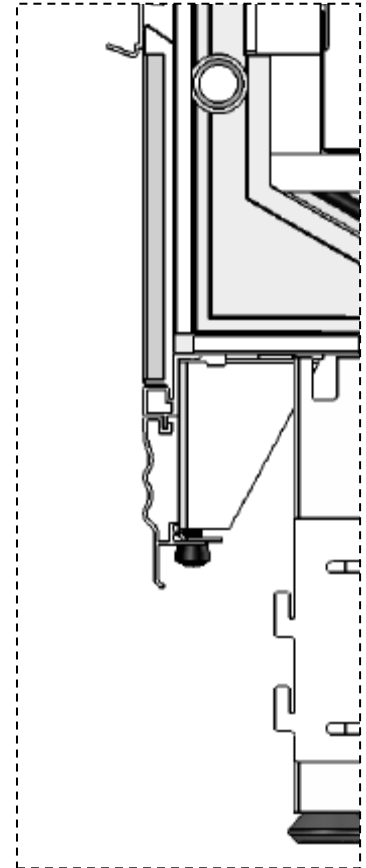

Kesit yan görünüş

➤ **Plastik tamponun montajı**

Assemble the plastic bumper to the bumper holder with your hand by pressing on it.



If the endwalls is to be assembled ,then the bumper ends must be assembled to the bumper. That's why cut the nails which are at the end of the bumper and attach it to the bumper aluminium as shown in Diagram 14.



Şekil 14

➤ **Assembling the Endwalls**

For being able to connecting endwalls, first of all stick the isolation tape to the panel plastic and to the body polyurethane supporter. (The surfaces that isolation tape must be sticked are shown in Diagram 13)

Place the sheet nuts to the sockets as it is shown in Diagram 14 . Bring the connection holes on the endwall and the connection components on the refrigerator same level. Tighten the nuts with screw. (Diagram 15) Attach the plastic cover to the holes.

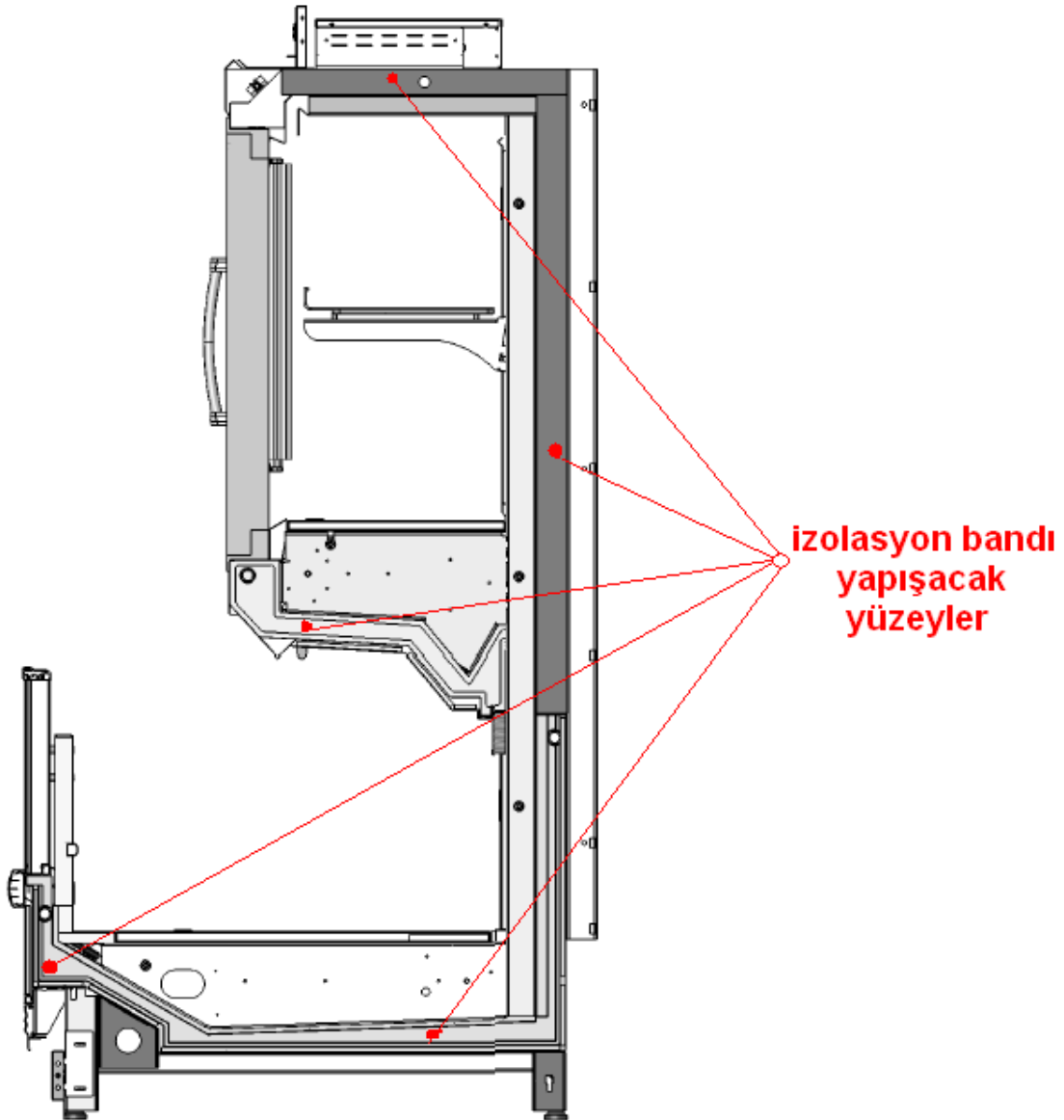

Şekil 13

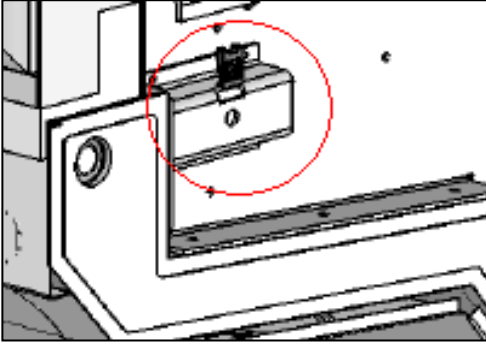

Şekil 14

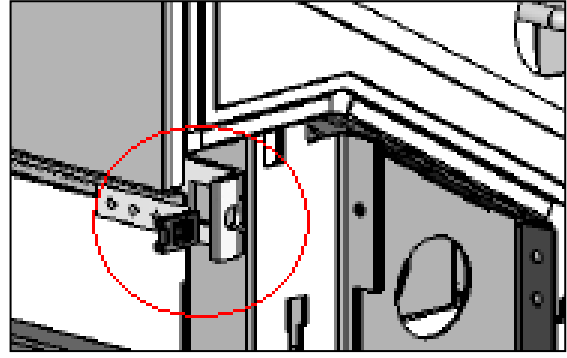

Şekil 15

The connection equipments that will be used for assembling the endwalls are shown in diagram below.

Poz No	Parça adı	Kullanım miktarı
1	Yan bağlantı sacı	Ürün üzerinde
2	Dolap bağlantı somunu Ø6.3x45	6
3	Baltic özel yan bağlantı sacı	Ürün üzerinde
4	Dolap yanı (sağ veya sol)	1
5	Vida sac 6k M6.3x45 Wurth	5
6	Ø 6 x 80 ağaç vidası	2
7	Beyaz plastik tapa	1
8	Tampon sonu	2
9	Baza topuzu	1
10	Yan baza	1
11	M6 özel somun	1
12	Yan baza bağlantı sacı	2
13	Taç sacı yan	1
14	Sac somunu 3,9 Wurth	2
15	Taç sacı yan destek (sağ veya sol)	1
16	Vida YSB 3,9x16	2
17	Deep freze cam yan profili	3
18	Deep Freze yan ısı cam	1
19	Deep Freze cam üst profili	1
20	Deep freze köşe dikme plastiği üst kapak (dar)	1
21	Deep freze köşe dikme plastik tampon	1
22	Deep freze tampon plastik profili	1

HDG L GLAZED PROFILED ENDWALL

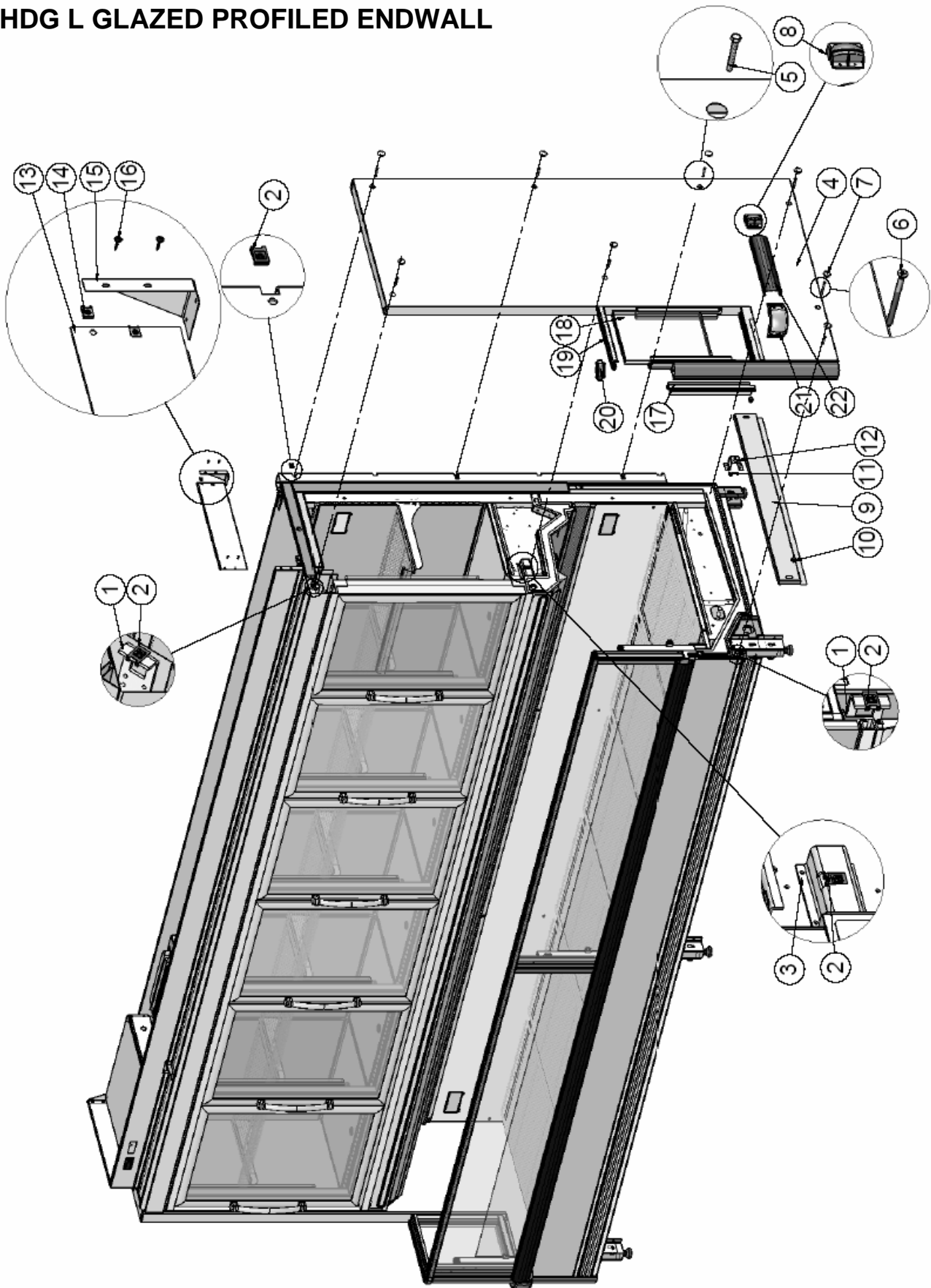

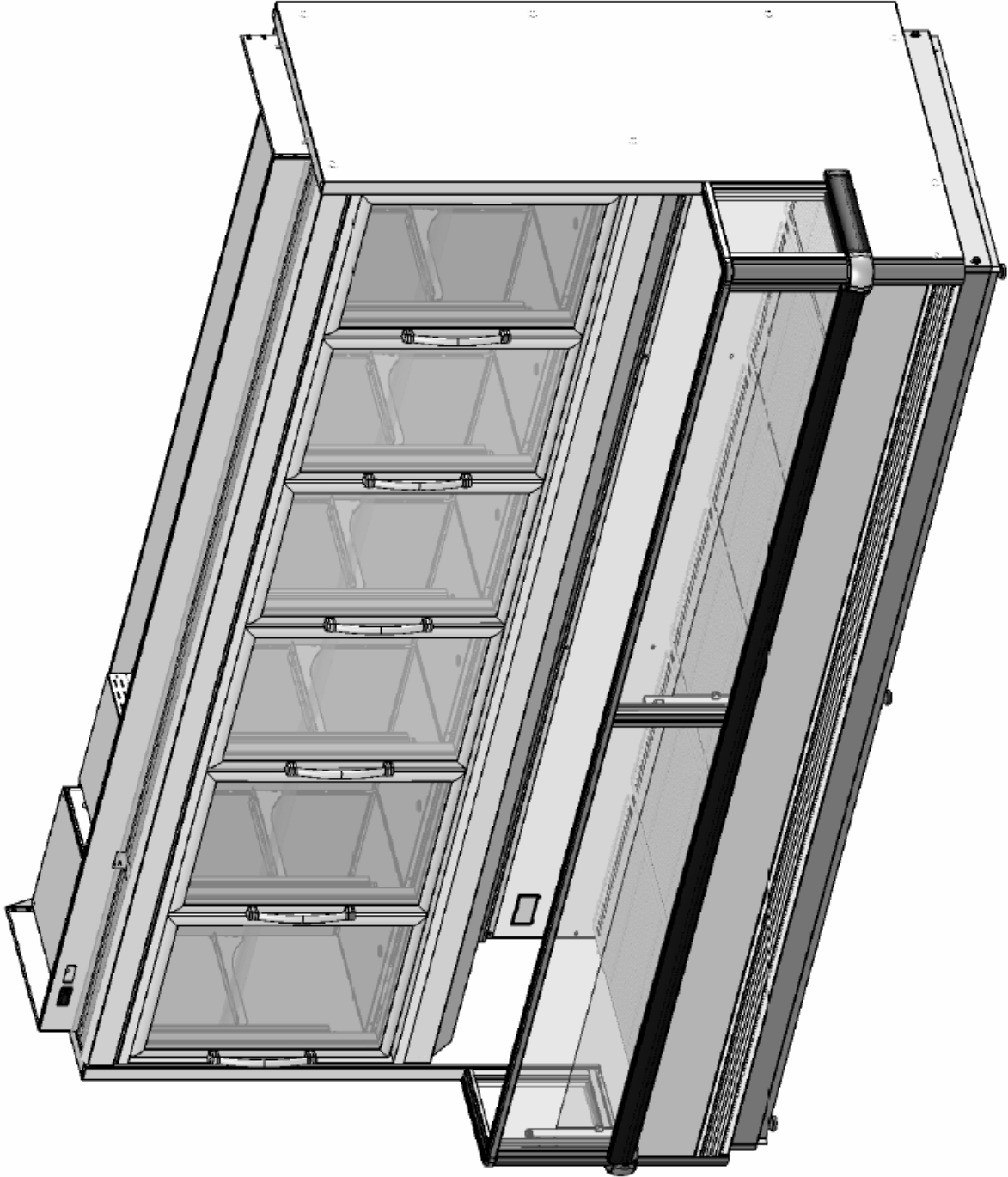

9. Kickplate Assembly

Kickplate is such an equipment that is located under the lower decor which covers the legs of refrigerator. . Kickplate is connected to the refrigerator leg by kickplate mace. Assemble the kickplate to the kickplate connection sheets which are located on the pillar legs as shown in Diagrams below.



Şekil 15



Şekil 18

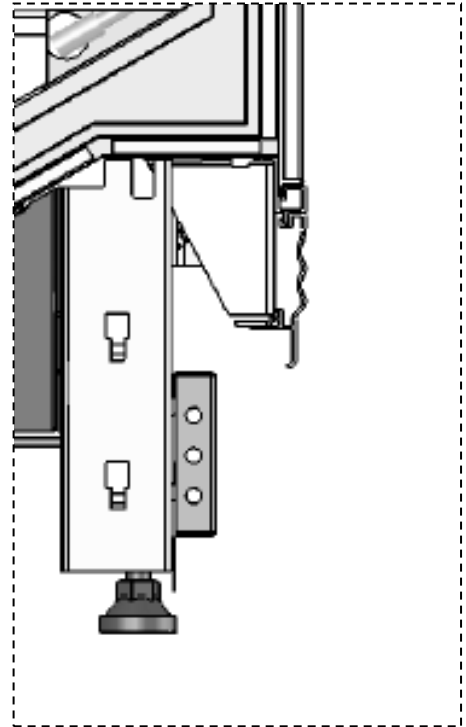

Kesit yan görünüş

10. Assembling the Shelf Bracket and Shelf

Shelf bracket is tied to back grill which is tied on the refrigerator pillar. Shelf bracket carries the refrigerator shelf. Attach the shelf bracket's upper nails on to the holes on the pillar. After you assembled the upper nails, attach the middle and lower nails. After you attached the nails on to the pillar, press on the brackets and make the nails fit well with the pillar. The nails which you attached on the pillar designates the angle of the shelf. (Diagram 20-21)

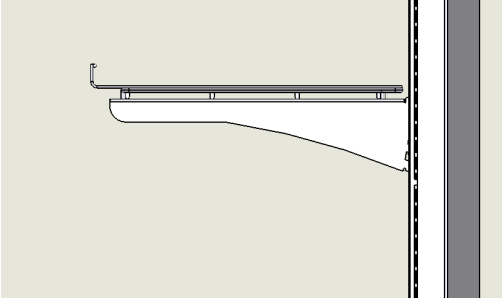

(Şekil 20) 0° raf konumu

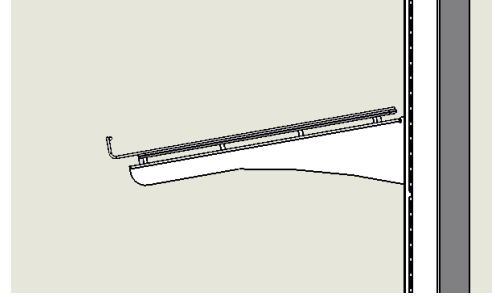

(Şekil 21) 10° raf konumu

For placing the shelf locate it between both brackets and release it on to the brackets (Diagram 22)

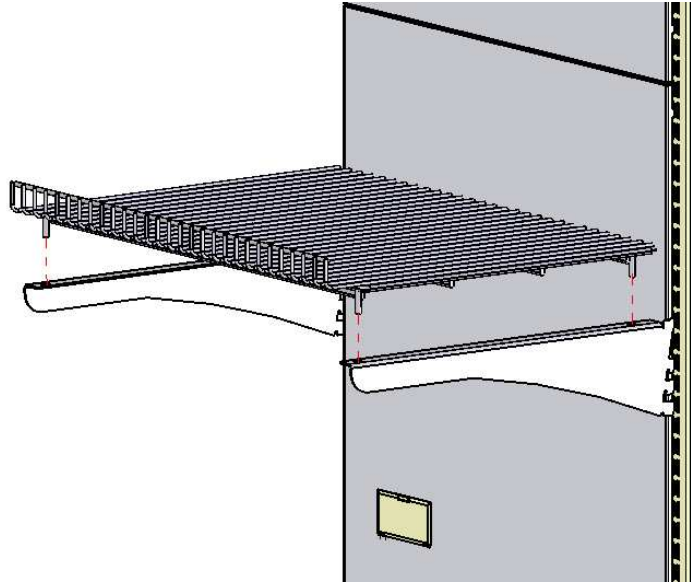

Şekil

DOOR INSTALLATION *REVERSIBLE DOOR*

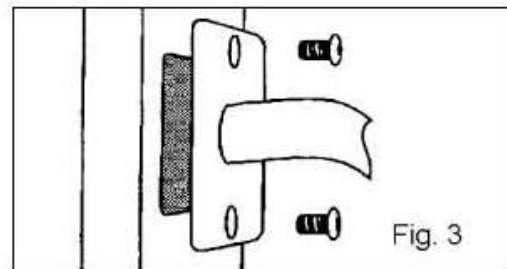
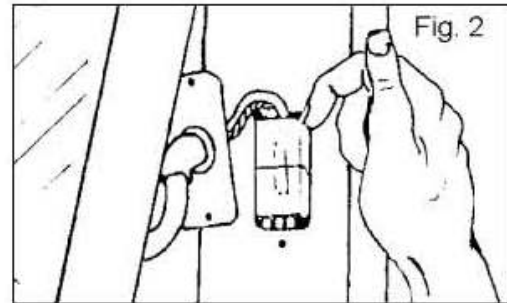
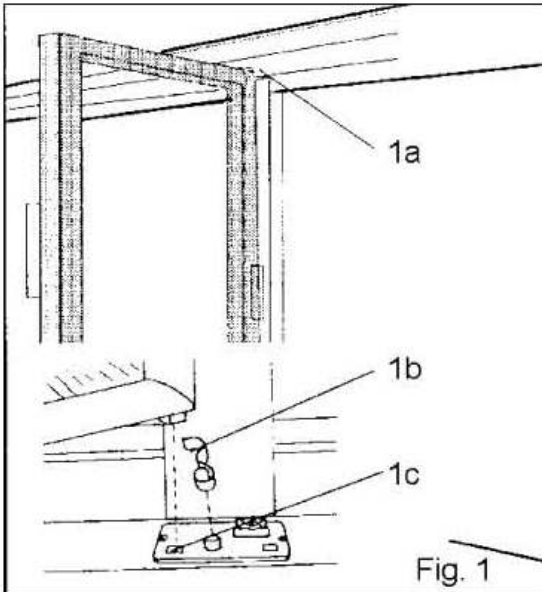

1. Lift door into frame to engage top door hinge pin into frame (1a).
2. Rest door on bottom of frame. Plug in door plug into frame and press it into the frame (2). Fasten cover plate where door cord exits (3).
3. Place door hold-open spring (1b) on mounting plate pin. Put door on hinge plate so that door pin fits into hole (1c). Swing door open or closed to drop door into proper position. Attention! Check that cable runs smoothly in door profile (4a).

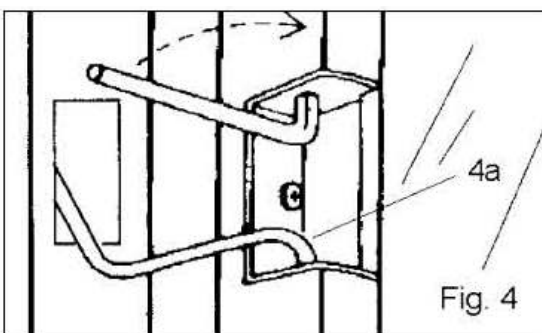

4. Adjust door closing tension by inserting an allen key (art No. 711301) into frame hole and rotate tool approx. three "clicks". Proper tension is achieved when door is opened approx. 20mm. and then closes by itself when released.

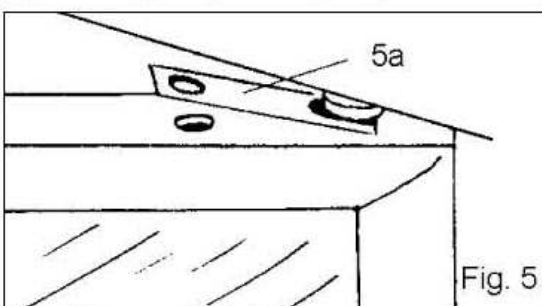

5. Screw on lock plate (5a) on top of door. It is important that this is done, in order to lock door safely in frame.

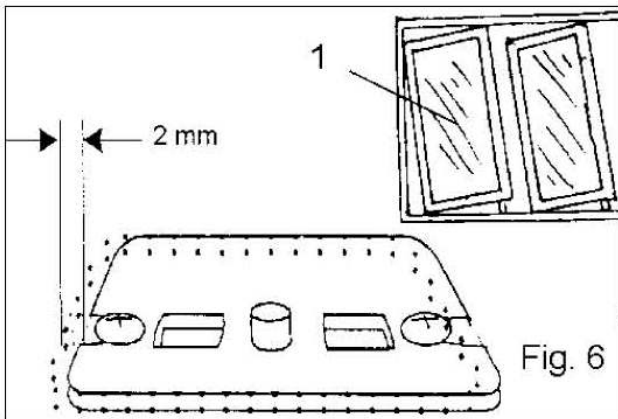

Fig. 6

6. After installation, if door appears to sag (1), unscrew screws on bottom mounting plate and adjust it to desired position. Bottom plate can be moved 2mm. in each direction.

Attention! Screws must be tightened even if bottom plate has not been adjust.

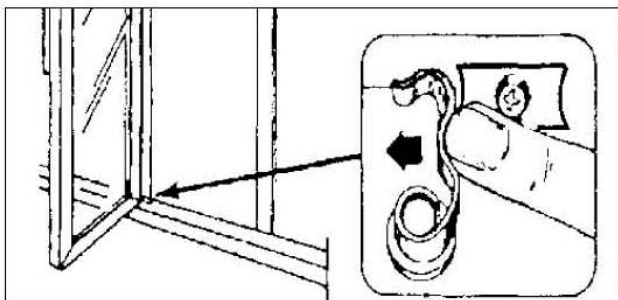

Fig. 7

DOOR HOLD-OPEN RETAINER

Attention! To keep door in open position, open door fully and push hold-open retainer, according to fig. To release, close door.

DOOR DISASSEMBLY

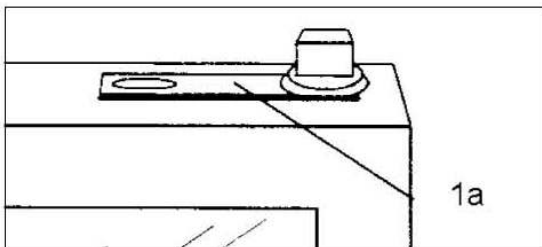

Fig. 1

1. Disconnect from power source. Open door and remove lock plate (1a, fig1).

2. Lift door up and out to disengage bottom door pin from mounting plate and rest door on bottom of frame. (fig 2)

3. Remove cover plate for door cable and disconnect electrical cord. (fig 3)

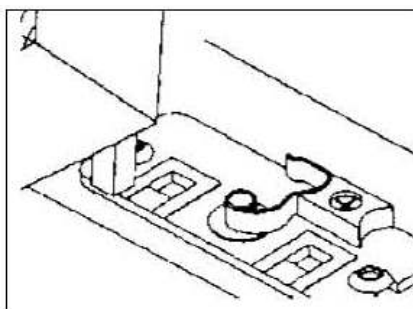

Fig. 2

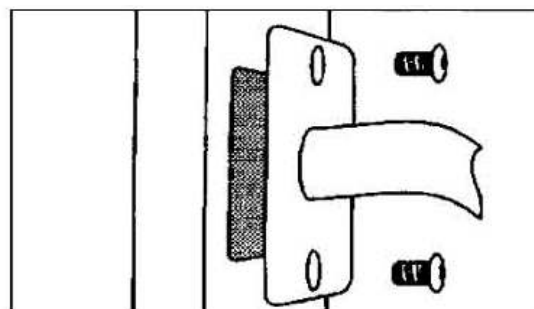
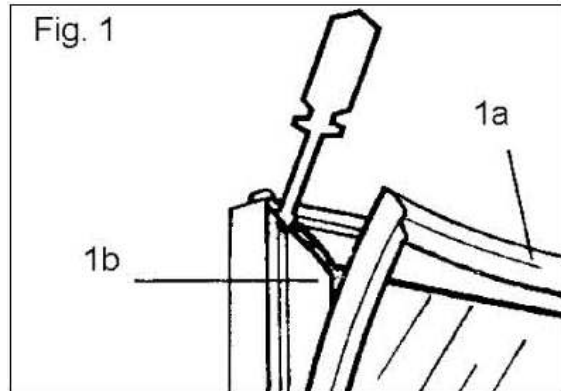

Fig. 3

DOOR SPRING REPLACEMENT

1. Disconnect frame from power source. Remove door as shown in “Door disassembly”. Remove magnetic gasket (1a) by starting on the upper corner and work your way down. Remove plastic cover (1b) with a screw driver, starting in the upper corner. If plastic cover is damaged it has to be replaced.



2. Remove locking pin (2a).

3. Replace spring mechanism (see page 10) Refit plastic cover by using a rubber hammer to get it into position properly. Use your finger to press magnetic gasket back into position. Reinstall door according to “Door installation”.

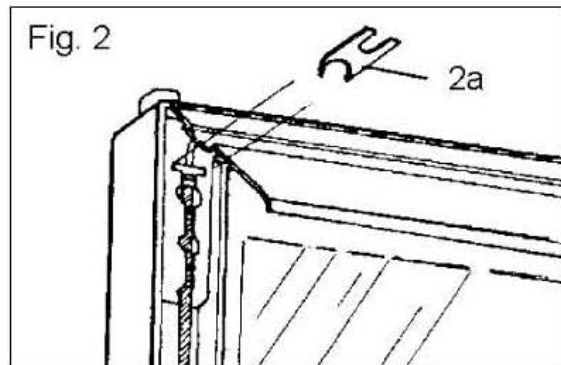

DOOR HINGE CONVERSION

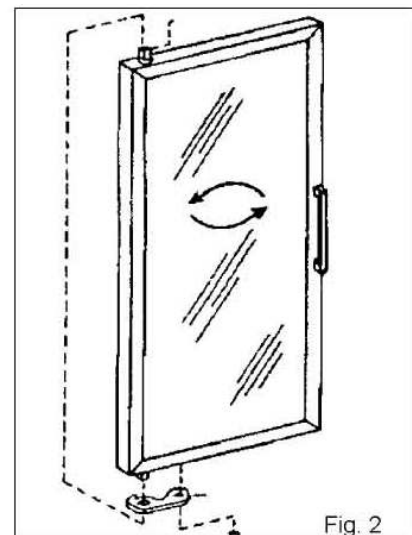
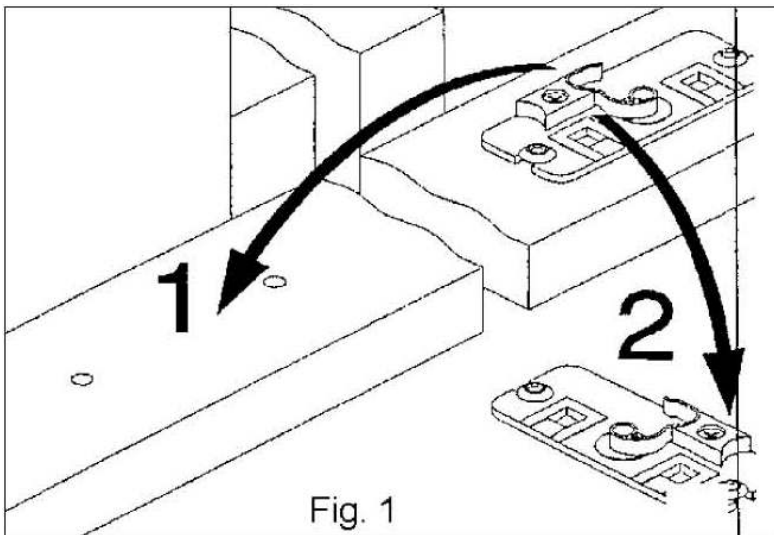

1. Disconnect frame from power source. Remove door according to “Door disassembly”.
 2. Remove door stop plate from bottom of door to opposite side, so that straight side of door stop plate faces front of door, fig 2.
 3. Remove mounting plate and protection plate and attach them on opposite side (1:1). Place hold open assembly on opposite side of mounting plate (1:2) Reinstall door according to “Door installation”.

REPLACING PLASTIC BUSHING

1. Remove door from frame.
2. How to replace plastic bushing is depending on type of door profile. If door profile is curved, hole of bushing should be placed outwards (fig 1a).
3. Remove hinge bushing with a screw driver. Install new bushing.
4. Reinstall door.

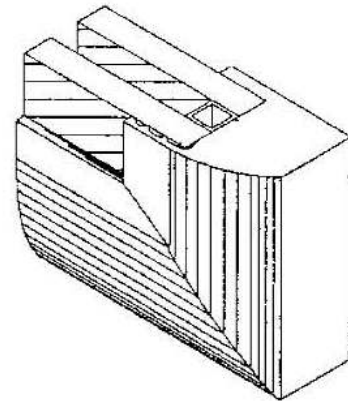
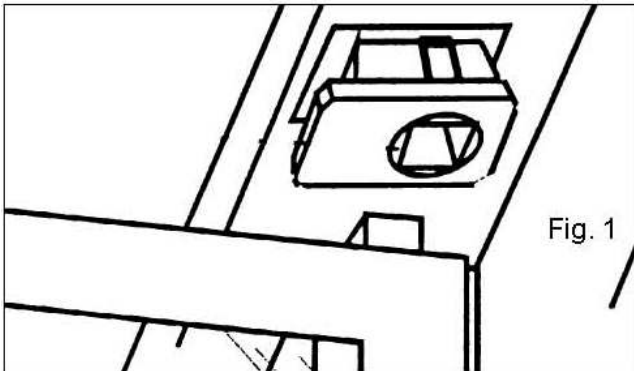

Standard door profile

REPLACING LIGHTING

Schott Termoform standard lighting

1. Press together lamp cover and twist outwards.
2. Twist light tube 90° clockwise or counter clockwise and remove it. Put in new light tube and reinstall lamp cover.

Attention! It is important that cover fits tightly against the aluminium profile. If air leaks in, light tube efficiency decreases.

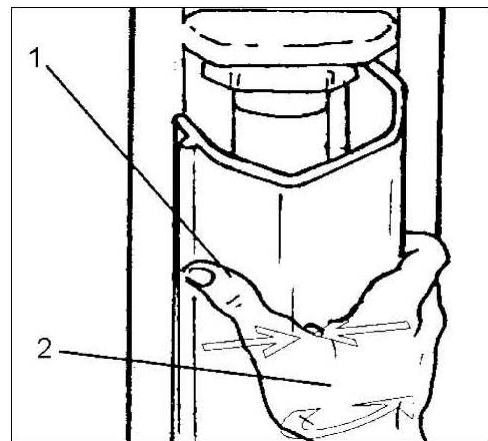

11. Electricity Connection

Details below must be examined while making the electricity connections.

Attention!! Examine the definition stickers, informations and electricity diagrams on the product guide before making the electric connections.

- Protective automatic key and main power switch must be used against electric current on the refrigerator.
- Users must know where the key is kept in case of an emergency
- **Electric systems must be grounded.**
- Maximum voltage difference must be guaranteed at %+-6.
- The thickness of the cable on the energy line must be at least 2,5 mm² and must put up with high current
- The cable of energy line must not be longer than 4-5m, depends on the conditions if cable length increases the cable cross-section must be increased too.
- For making the refrigerator works regularly, be sure you obtained the heat and the damp values which are regarded at EN441 and be sure the climate class is 3.

The personnel who will interfere to the refrigerator must have electricity certificate.

12. Heat Control

Heat control is operated by the digital thermostat which is Assembled to the upstand on the refrigerator.(Diagram 23)

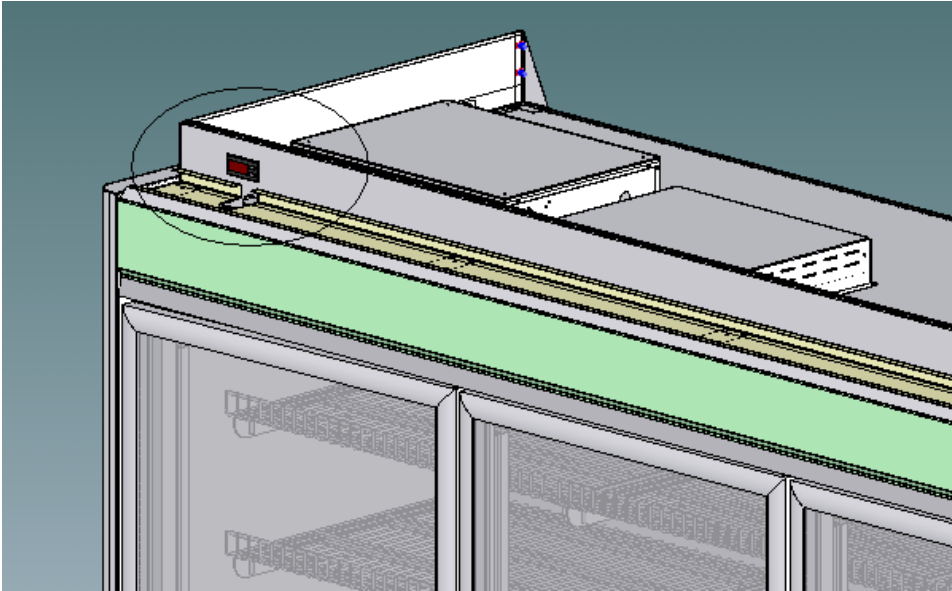

Şekil 23

Important: Maximum 3 units of cabinet's control must be obtained with a pilot module.

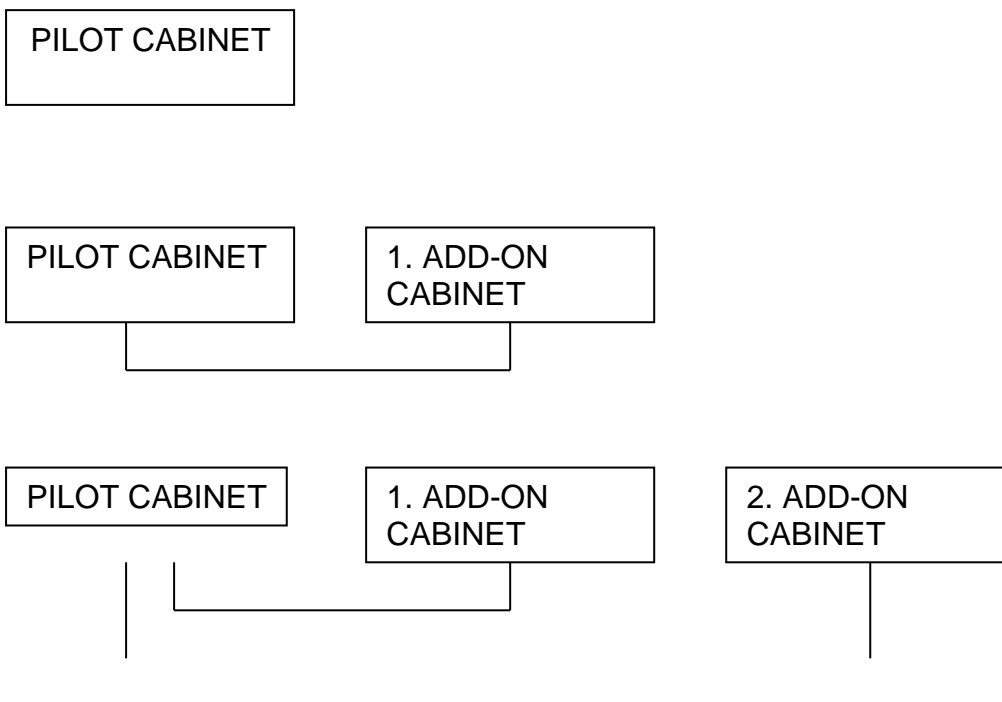

13. Loading Goods

These important rules must be followed while the refrigerator is loading.

- Locate the goods to the shelves tidy. Maximum loading limit is approximately 160 kg. on a shelf. Do not load over 160 kg.
- Shelves can be adjusted in different angles. (0°,10°) (Diagram 24)

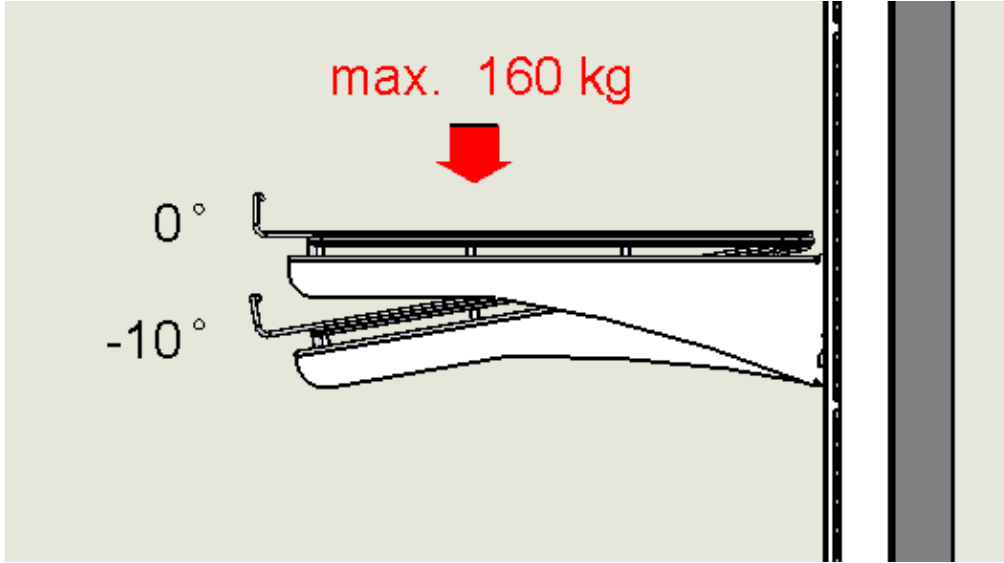

Şekil 24

- For being able to load the refrigerator fully adjust the goods and do not leave empty spaces
- Leave at least 30mm space between the loaded goods and the shelves.
- Make the loading as the same product which is loaded firstly would always be loaded.
- Do not load any goods to the refrigerator except the refrigerator's shelves and base displates.

14. Defrost and Drainage

Defrosting is obtained by resistance at Baltic refrigerator

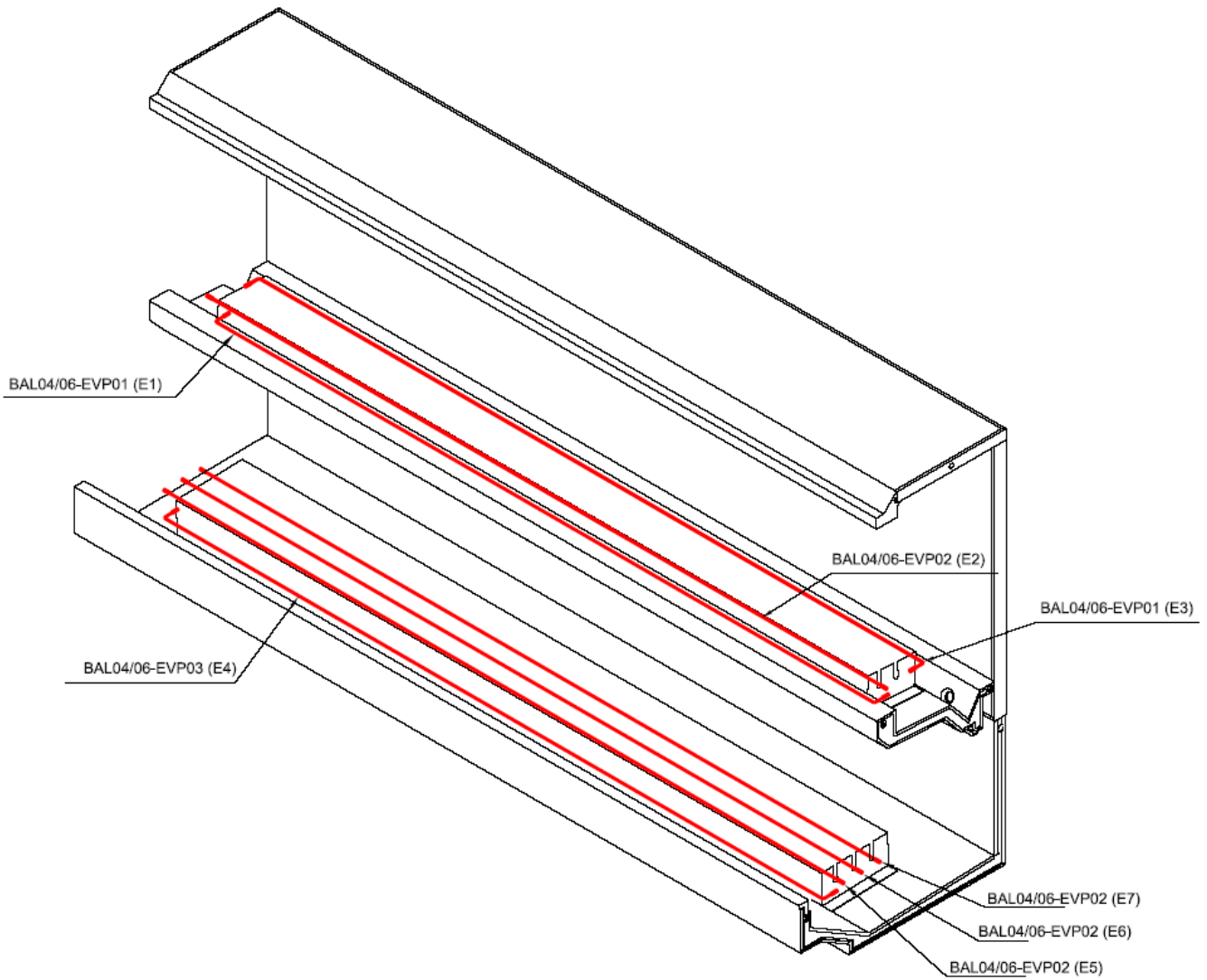

Sending the defrost water out;

- Make the base connection with the refrigerator's drainage piece.
- Prepare the water siphon and connect it to the water way

Way to prepare the water emptying system (Diagram 25, 26 ve 27),



Şekil 25



Şekil 26

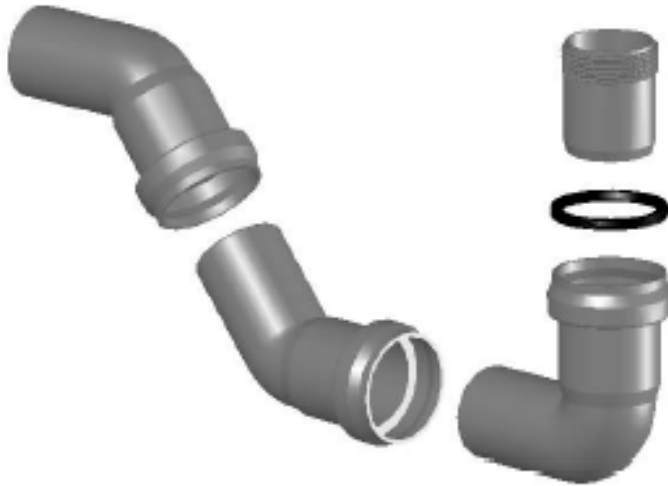

Şekil 27

- There must be some water placed as much as it fills the water emptying siphon before the refrigerator's first working attempt is made.

These procedures prevent the bad smell of refrigerator, avoiding of cold weather and also prevent refrigerator perspiration. The drainage places of the refrigerator as to module is shown below.

Baltic lower body drainage location;
üst görünüş

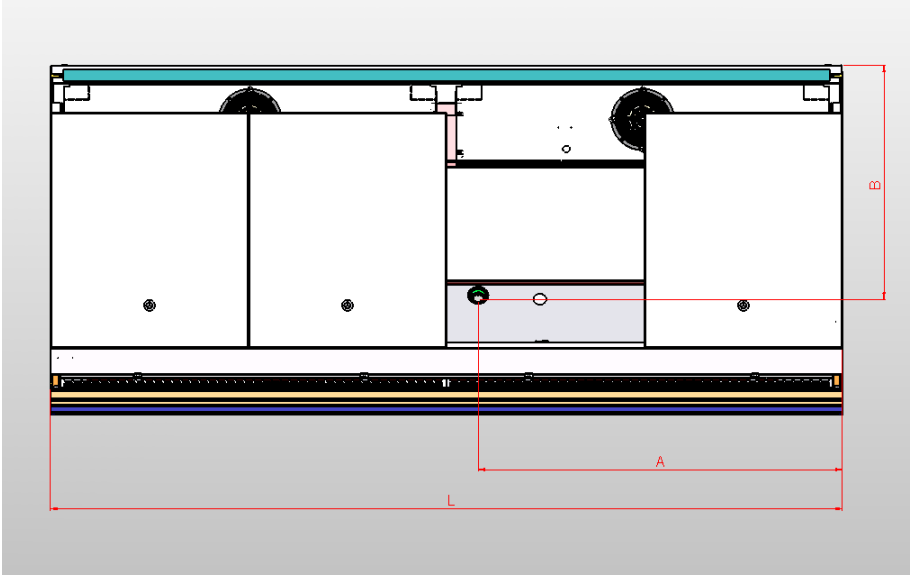

MODÜL (L)	2500	3750
A (mm)	1150	1775
B (mm)	740	740

Baltic upper body drainage location ;
arka görünüş

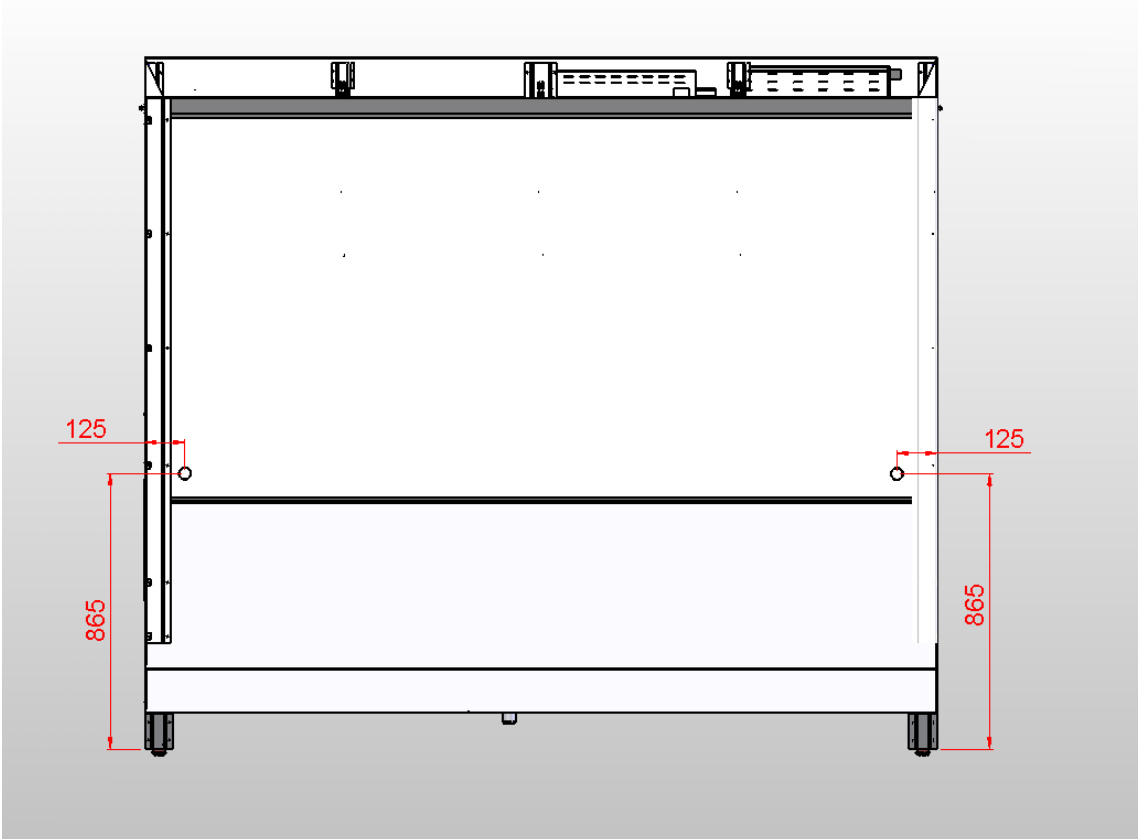

15. Valve Location

The valve on the Arctic refrigerator is located on right part of the refrigerator behind the evaporator near the fan sheet just as it is shown on Diagram 28 and 29.

Baltic lower body electronical valve location;
üst görünüş

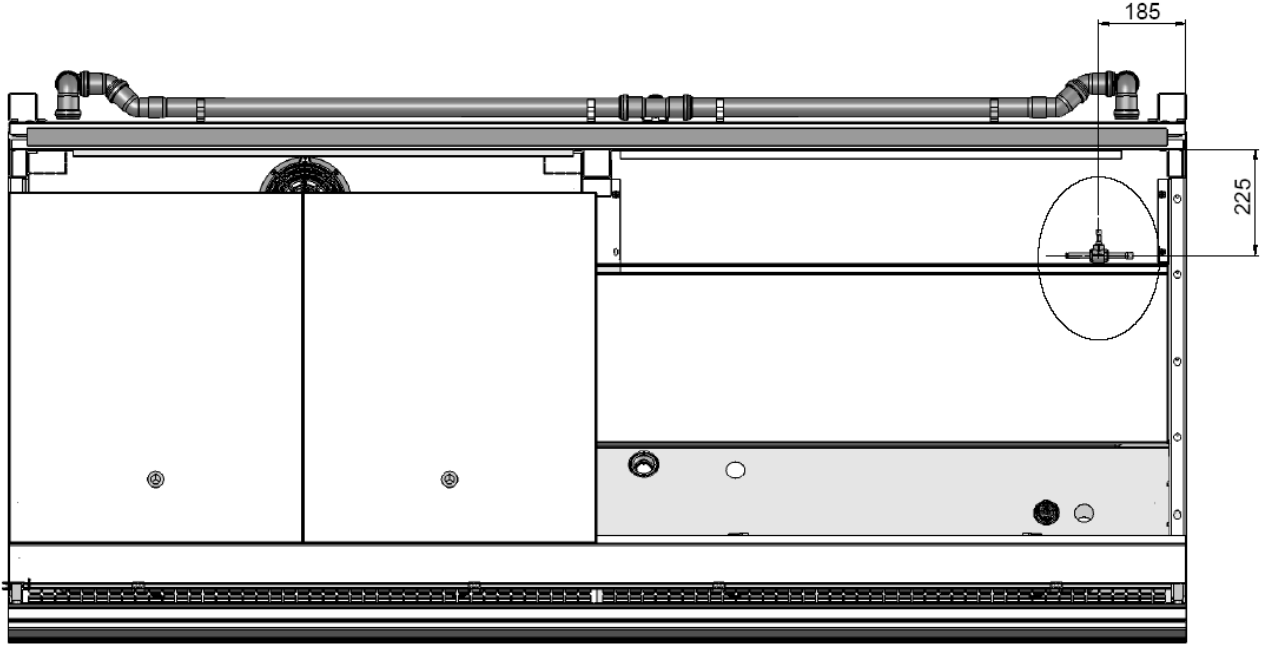

Şekil 28

Baltic lower body electronical valve location;
üst görünüş

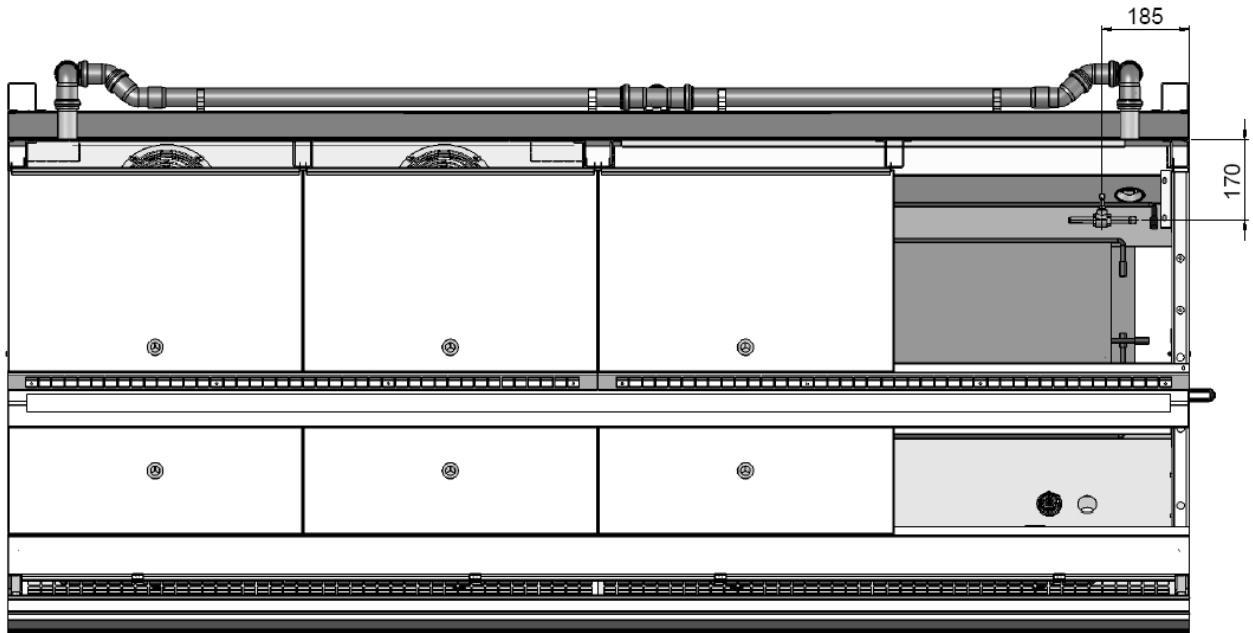

Şekil 29

16. Care, Cleaning and Technical Service

Attention!! Make sure there is no electricity connection or the main power switch is turned off, before attempting any care and cleaning activities

It is a must for you to materialize your refrigerator's care and cleaning activities periodically. Cleaning section must be done by the users, such as cleaning the inner and outer surfaces of the refrigerators.

Before you start cleaning your refrigerator turn off the cooling and illumination keys. Remove the goods inside the refrigerator to somewhere else during the cleaning activity where the goods would not spoil. Do not remove the base displates during the cleaning. Cleaning of the refrigerator must be done just as written below.

Do not use alcohol during the cleaning

Use gloves for protecting your hands during the whole cleaning

- **First step cleaning**

After taking the delivery of:

- Be sure the package is not damaged
- Unpack the refrigerator without harming it
- Be sure all the pieces are undamaged and packed well.
- Apply the steps or cleaning the refrigerator
- Make contact with the provider company about any damage.
 - **Cleaning the outer pieces** (Daily/Weekly)
 - Clean the outer pieces of the refrigerator once a week with detergent and soap.
 - Clean with soft gland and pure water.
 - Do not use any matters or solvent that could damage the outer surface.
 - Do not contact the parts which are related with electricity with water or detergent.
 - Do not use alcohol for cleaning the plexiglass.
 - **Cleaning the inner pieces** (Monthly)

The reason of cleaning the inner side of the refrigerator is preventing the constitution of micro organisms so that the foods would be protected more efficiently.

- Remove all the foods inside.
 - Cut the electricity connection or turn off the main power switch.
- Disassemble all the piece that could be disassembled. For example base tray , air return gril etc. Clean it with the hot chemical water and dry it.
- Clean the base trays carefully and pay attention to the unknown materials do not contact with the fans
 - Contact with the authorized service if any abnormal situation occurs.

Re-place all the refrigerator equipment that you've disassembled from the refrigerator after you've finished the cleaning and connect the refrigerator to the electricity. Turn on the illumination and cooling keys after you've finished cleaning your refrigerator.

P.S. : Be sure the fans, the illumination pieces, the electrical cables and the other equipments are dry.

▪ **Technical Service:**

Please read the guide carefully. By this way the call center operator could be more helpfull.

- Be sure the environmental heat and the moisture are not so different than the recommended values.
- Be sure the food packages do not connect with daylight directly.
- Isolate the store's Windows against daylight.
- Do not point the spotlights on to the refrigerator directly.
- Do not let the air grills blocked.
- Use the refrigerator for only keeping the cooled goods.
- Be sure the refrigerator cools constantly. Check on the refrigerator twice a day
- Load the refrigerator as to loading limits, do not overload.
- Empty the refrigerator immediately if any failure occurs.
- If any of the screws falls or if any of the lamp goes off change it immediately.
- Check on the automatic defrost periodically.
- Be sure there is no abnormal water condensing, if so then contact with cooling technician immediately.
- Make the periodical cares continual.

Cabinets could give failure even you make the cleaning and care activities. When you realize that the refrigerator does not operate move as to the instructions below:

- Is cooling key switched on?
- Is everything normal at the cooling system's electricity box?
- Is there power?

If the answer of the question above are yes, then there is a problem with cabinet, with condensing unit or with installation. **Contact with the technical service**. Till the technical service arrives, remove all the goods in the refrigerator to somewhere else as soon as possible.

IN CASE OF GAS LEAK AND FIRE; Do not stay in the room if there is no air circulation. Plug off the refrigerator. **DO NOT USE WATER TO PUT OUT THE FIRE. ONLY USE FIRE EXTINGUISHER.**

17. Separating the pieces as to recycling

Every country provides the recycling by separating the refrigerator's pieces as to their local environmental laws.

Pieces that used for the refrigerator;

- Painted sheets : Pillars,shelves,legs
- Copper, aluminium :Cooling circuit, electricity system ve ceiling illumination
- Galvanize sheets :Lower panels, painted panels, simple pieces, shelves, base trays
- Polyurethan foam :Thermal injections
- Isıcam :Glasses
- Wooden :Corners of the foamed bodies
- PVC :Bumper and plastics on the windows
- Polistiren :Termoform endwalls
- Polikarbon :Lamp protection tubes

18. SPARE PARTS

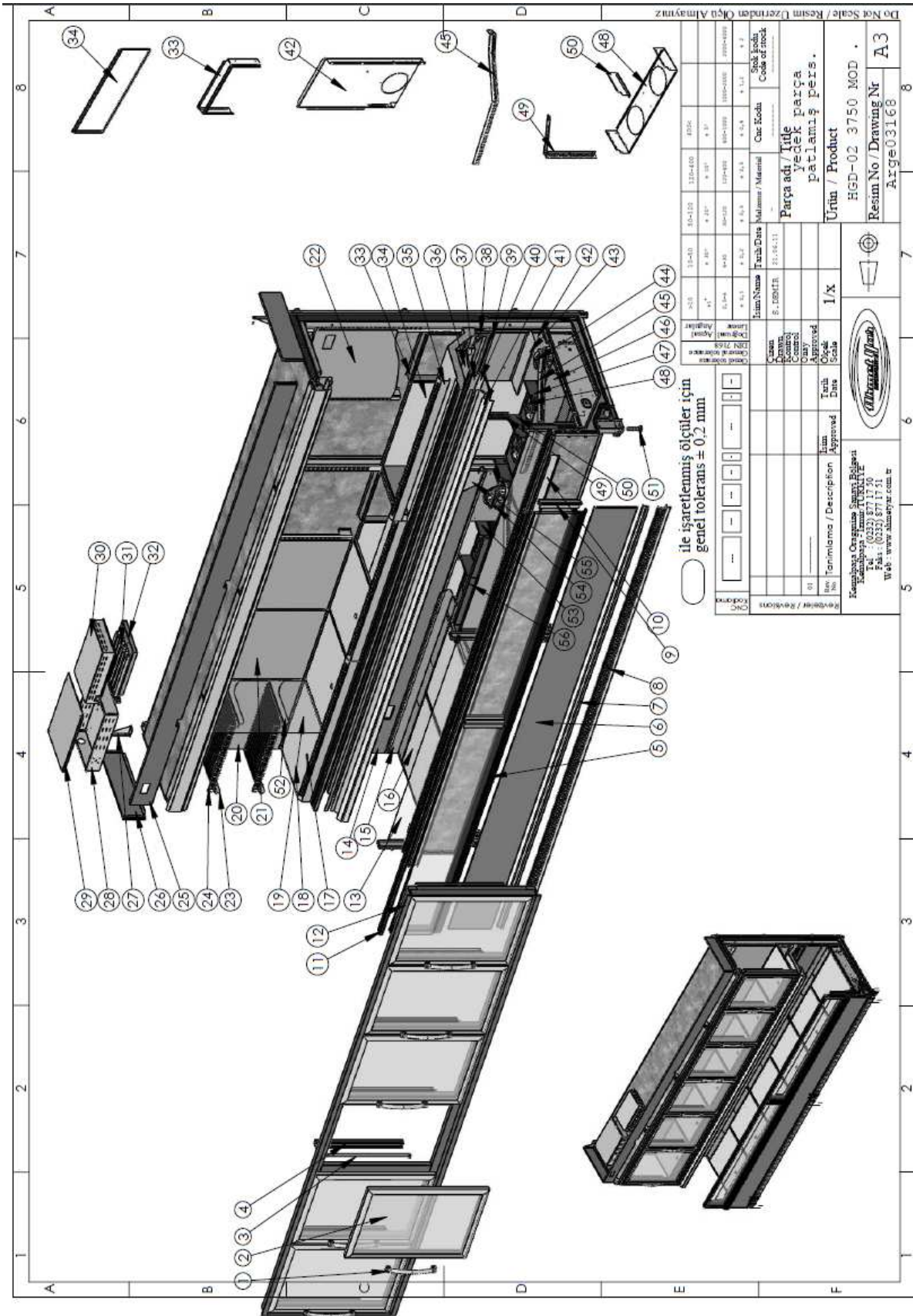

HGD2 YEDEK PARA LİSTESİ

NO	PARA ADI	STOK KODU
1	KAPI KULBU	
2	KAPI	
3	FLOROSAN	
4	FLOROSAN KAPAĐI	
5	TAMPON PLASTİĐI	
6	DEKOR SACI	
7	ALT DEKOR ÜST ALÜMİNYUMU	
8	ALT DEKOR ALT ALÜMİNYUMU	
9	DEEPFREEZE CAM YAN PLASTİK PROFİLİ	
10	TAMPON TUTUCU ALÜMİNYUM PROFİL	
11	DEEPFREEZE CAM ÜST PLASTİK PROFİLİ	
12	ÖN CAM	
13	İÇ CAM	
14	ARKA TAVA OTURTMA ÜST SACI	
15	ARKA TAVA OTURTMA ALT SACI	
16	ALT TAVA SACI	
17	TAVA PLASTİĐI	
18	ÜST TAVA SACI	
19	SİSTEM BÖLÜCÜ PLEKSİ	
20	ARKA TEL SACI SOL	
21	ARKA TEL SACI ORTA	
22	ARKA TEL SACI SAĐ	
23	RAF KOLU SOL	
24	RAF TELİ	
25	TAÇ SACI	
26	TAÇ SACI YAN	
27	TAÇ SACI YAN DESTEĐİ	
28	ELEKTRİK KUTUSU	
29	ELEKTRİK KUTUSU KAPAĐI	
30	BALAST KUTUSU KAPAĐI	
31	BALAST	
32	BALAST KUTUSU ALT SACI	
33	EMİŐ BYPASS SACI-3	
34	ÜFLEME BYPASS SACI-2	
35	ÜST BÖLÜM ÖN EMİŐ SACI	
36	ORTA GÖVDE ALT KAPAMA SACI	
37	ORTA GÖVDE ÖN KAPAMA SACI	
38	ARI PETEĐİ	
39	ARI PETEĐİ ALT BAĐLANTI SACI	
40	ORTA GOVDE ALT ETIKETLIK SACI	
41	ETİKETLİK PLASTİĐİ	
42	FAN EMİŐ SACI-2	
43	EMİŐ BYPASS SACI-2	
44	FAN ÇEMBERİ	
45	EMİŐ DİRENÇ SACI	
46	EVAP ÖRTME SACI	

47	ÜFLEME FAN SACI KISA	
48	FAN KANADI	
49	ÜFLEME DİRENÇ SACI	
50	FAN DESTEK SACI	
51	AYAK VİDASI	
52	RAF KOLU SAĞ	
53	ÜFLEME FAN SACI UZUN	
54	FAN MOTORU	
55	ARKA İÇ HAVA DAĞITICI SACI	
56	ÜFLEME BYPASS SACI	

19. Elektrik şemaları

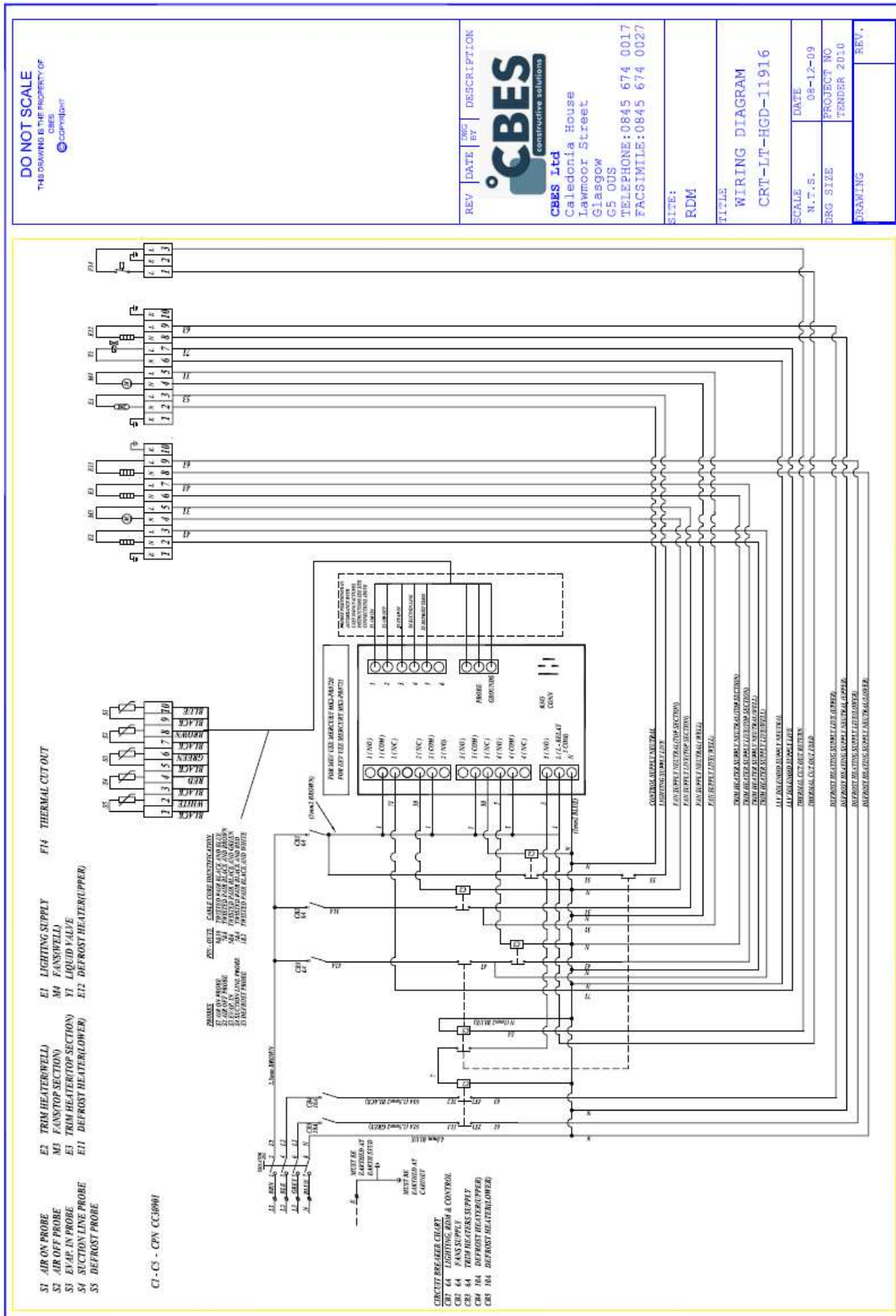

CAREL PARAMETERS		ISLAND FREEZER	WALL FREEZER	COMBI FREEZER	UPRIGHT FREEZER	COUNTER	MULTIDECK CABINET
/Pro (Prob parameters)							
/2	Measurement stability		4	4	4	4	4
/4	Virtual Prob: Blowing and suction probes rates for regulation		100	100	100	50	50
	0= Blow probe						
	100= Suction probe						
/5	°C or °F selection		0	0	0	0	0
	0=°C, 1=°F						
/6	Decimal		1	1	1	1	1
	0=active,						
	1= inactive						
rHS	Virtual probe regulation rate to calculate glass temperature		20	20	20	20	20
	0= Blow probe						
	100= Suction probe						
/t	Are signals and alarms viewed in non-button terminal?		0	0	0	0	0
	0= inactive						
	1= active						
/t1	probe to be viewed in button terminal		12	12	12	12	12
	0 = Terminal inactive	8 =Serial probe 8					
	1 = Probe 1	9 =Serial probe 9					
	2 = Probe 2	10 =Serial probe 10					
	3 = Probe 3	11 =Serial probe 11					
	4 = Probe 4	12 = Control probe					
	5 = Probe 5	13 = Virtual probe					
	6 = Probe 6	14 = Set point					
	7 = Probe 7						
/t2	probe to be viewed in non-button terminal		12	12	12	12	12
	0 = Terminal inactive	8 =Serial probe 8					
	1 = Probe 1	9 =Serial probe 9					
	2 = Probe 2	10 =Serial probe 10					
	3 = Probe 3	11 =Serial probe 11					
	4 = Probe 4	12 = Control probe					
	5 = Probe 5	13 = Virtual probe					
	6 = Probe 6	14 = Set point					
	7 = Probe 7						

CAREL PARAMETERS			ISLAND FREEZER	WALL FREEZER	COMBI FREEZER	UPRIGHT FREEZER	COUNTER	MULTIDECK CABINET
/to	button/non-button terminal configuration		3	3	3	3	3	3
	Button terminal	Non-button terminal						
	0 Yes	yes						
	1 optional	yes						
	2 Yes	optional						
3 optional	optional							
/P1	S1 ,S2 , S3 (Group 1) probe type		0	0	0	0	0	0
	0 = NTC Standard Range -50T90°C							
	1 = PTC Standard Range -50T150°C							
	2 = PT1000 Standard Range -50T150°C							
	3 = NTCL243 Standard Range -50T90°C							
/P2	S4 ,S5 (Group2) probe type		0	0	0	0	0	0
	0 = NTC Standard Range -50T90°C							
	1 = PTC Standard Range -50T150°C							
	2 = PT1000 Standard Range -50T150°C							
	3 = NTCL243 Standard Range -50T90°C							
/P3	S6 (Group3) probe type		4	4	4	4	4	4
	0 = NTC Standard Range -50T90°C							
	1 = PTC Standard Range -50T150°C							
	2 = PT1000 Standard Range -50T150°C							
	3 = NTCL243 Standard Range -50T90°C							
4 = 0 to 5V ratiometric pressure transmitter								
/P4	S7, (Group4) probe type		0	0	0	0	0	0
	0 = NTC Standard Range -50T90°C							
	1 = PTC Standard Range -50T150°C							
	2 = PT1000 Standard Range -50T150°C							
	3 = NTCL243 Standard Range -50T90°C							
	4 = 0 to 5V ratiometric pressure transmitter							
	5 = 0 to 10 V input							
6 = 4 to 20 mA input								
/P5	S8 den S11 e (Group5) serial problar probe type		0	0	0	0	0	0

CAREL PARAMETERS		ISLAND FREEZER	WALL FREEZER	COMBI FREEZER	UPRIGHT FREEZER	COUNTER	MULTIDECK CABINET
CtL (Control)							
OFF	ON/OFF control unit on-off 0 = ON; 1 = OFF;	0	0	0	0	0	0
St	Set point	-20	-20	-20	-20	0	2
St2	Double thermostate control suction set value	50	50	50	50	50	50
rd	St set value difference	2	2	2	2	2	2
rd2	Double thermostate control suction set value difference 0.0 = Function inactive	0	0	0	0	0	0
r1	Allowed minimum set value	-24	-24	-24	-24	-4	-4
r2	Allowed maximum set value	-18	-18	-18	-18	4	4
r3	Defrost warning activation ending in time 0 = inactive, 1 = active	0	0	0	0	0	0
r4	Automatic night set point	0	0	0	0	0	0
r5	Will minimum and maximum temperatures be kept to which probe in the memory?		1	1	1	1	1
	0 = Monitoring inactive	6 = superheat temperature probe (tGS)					
	1 = Control probe (Sreg)	7 = saturated evaporation temperature probe (tEu)					
	2 = virtual probe (Sv)	8 = auxiliary defrost probe (Sd2)					
	3 = Blow probe (Sm)	9 = auxiliary probe (Saux)					
	4 = defrost probe (Sd)	10 = auxiliary probe 2 (Saux2)					
rt	Recorded min and max temperature monitoring time range	-	-	-	-	-	-
rH	Recorded max temperature	-	-	-	-	-	-
rL	Recorded min temperature	-	-	-	-	-	-
r6	Night Control probe 0 = virtual probe Sv; 1 = Suction probe Sr	0	0	0	0	0	0
ro	For Virtual Probe, probe error offset	0.0	0.0	0.0	0.0	0.0	0.0
r7	Master solenoid valve configuration 0 = local valve ;1 = network valve (connected to the Master)	0	0	0	0	0	0
rSu		0	0	0	0	0	0

CAREL PARAMETERS			ISLAND FREEZER	WALL FREEZER	COMBI FREEZER	UPRIGHT FREEZER	COUNTER	MULTIDECK CABINET
CMP (compressor)								
c0	Compressor and fan starting time delay		0	0	0	0	0	0
c1	Minimum time between successive start		0	0	0	0	0	0
c2	Compressor minimum OFF Time		0	0	0	0	0	0
c3	Compressor minimum ON Time		0	0	0	0	0	0
c4	Control probe error duty time. Compressor and solenoid outlet works for the time stated there		0	0	0	0	0	0
	holds for 15 minutes and works again.							
	0 = Compressor/valve always OFF; 100 = compressor/valve always ON							
cc	Continuous cycle time		1	1	1	1	1	1
c6	Post-continuous cycle alarm by-pass		60	60	60	60	60	60
c7	Maximum pump down time		0	0	0	0	0	0
Def (defrost)								
d0	Defrost type		4	0	0	0	0	0
	0 =temperature-based heater	4 =time and temperature-based heater defrost						
	1 = temperature-based hot gas	5 =temperature-based heater multiplied hotgas bypass						
	2 = temperature-based heater	6 =time-based heater multiplied hotgas bypass						
	3 = time-based hot gas							
d2	Defrost-end synchronization by Master		1	1	1	1	1	1
	0 = unsynchronous; 1 = synchronous							
d1	Time between defrosts		8	8	6	6	6	6
dt1	Defrost-end temperature, Evaporator Sd1		10	10	12	12	10	10
dt2	Defrost-end temperature,AUX Evaporator Sd2		10	10	12	12	10	10
dP1	Maximum Defrost time		35	35	40	45	45	45
dP2	Maximum Defrost time, AUX 2. Evaporator		35	35	40	45	45	45
d4	Initially defrost		0	0	0	0	0	0
	0 = No initial defrost ; 1 = inital defrost							
	(Master = network defrost; Slave = local defrost)							
d5	Defrost time delay at the beginning if d4=1		0	0	0	0	0	0
	0 = delay inactive							
d6	Terminal indicator status during defrost		2	2	2	2	2	2
	0 = Real temperature value and "dEF" flashes							
	1 = pre-defrost last temperature remains on the screen							
	2 = 'dEF' is viewed							
dd	Post-Defrost drip time		2	2	2	2	2	2
	0= No drip							

CAREL PARAMETERS		ISLAND FREEZER	WALL FREEZER	COMBI FREEZER	UPRIGHT FREEZER	COUNTER	MULTIDECK CABINET	
d7	defrost by-pass	0	0	0	0	0	0	
	0 = inactive ; 1 = active;							
d8	Alarm delay following defrost and door opening	30	30	30	30	30	30	
d9	Status of compressor protection times in hotgas bypass	1	1	1	1	1	1	
	0 = protection times are followed ; 1 = protection times are ignored							
Sd1	Defrost Probe value	-	-	-	-	-	-	
Sd2	Second Evaporator defrost probe value	-	-	-	-	-	-	
dC	Defrost time basis	0	0	0	0	0	0	
	0 = dl hour,dP1,dP2 and ddP minute; 1 = dl minute,Dp2 and ddP second							
d10	Time for defrost based on lamel temperature	0	0	0	0	0	0	
	0 = Function inactive							
d11	Temperature-based defrost activation temperature threshold	-30	-30	-30	-30	-30	-30	
d12	During Defrost, pressure transmitter alarm status	0	0	0	0	0	0	
	probe failure							failure in supervisor
	0 inactive							active
	1 active							active
	2 inactive							inactive
3 active	inactive							
dS1	Compressor stop time for successive defrost (when stops for this time, defrost ends,	0	0	0	0	0	0	
	0 = Function inactive							
dS2	Compressor operation time for successive defrost (defrost starts when the	120	120	120	120	120	120	
ddt	Defrost end temperature offset for Power defrost	0.0	0.0	0.0	0.0	0.0	0.0	
ddp	Defrost time offset for Power defrost	0	0	0	0	0	0	
dn	Nominal Defrost bypass time rate	75	75	75	75	75	75	
d1S	daily defrost based on td1 time zone	0	0	0	0	0	0	
	0 = inactive							8 = 3 hours 0 minute
	1 = 24 hours 0 minute							9 = 2 hours 40 minutes
	2 = 12 hours 0 minute							10 = 2 hours 24 minutes
	3 = 8 hours 0 minute							11 = 2 hours 11 minutes
	4 = 6 hours 0 minute							12 = 2 hours 0 minute
	5 = 4 hours 48 minutes							13 = 1 hour 0 minute
	6 = 4 hours 0 minute							14 = 30 minutes
7 = 3 hours 26 minutes								

CAREL PARAMETERS		ISLAND FREEZER	WALL FREEZER	COMBI FREEZER	UPRIGHT FREEZER	COUNTER	MULTIDECK CABINET
d2S	see d1S parameter for td1 time zone daily defrosts	0	0	0	0	0	0
dH1	Pumpdown time	0	0	0	0	0	0
	0= pump down inactive						
dHG	Multiplied hot gas bypass type	0	0	0	0	0	0
	0 = Compensator valve is OFF usually						
	1 = Compensator valve is ON usually						
ALM (Alarm)							
AA	Determination of temperature probe for AH and AL alarms		1	1	1	1	1
	1 = control (sreg)	8 = auxiliary defrost probe (Sd2)					
	2 = virtual (Sv)	9 = auxiliary probe (Saux)					
	3 = blow (Sm)	10 = auxiliary probe 2 (Saux2)					
	4 = defrost (Sd)	11 = ortam sıcaklığı (SA)					
	5 = suction (Sr)	12 = ortam nemi (SU)					
	6 = superheat temperature probe(tGS)	13 = cam sıcaklığı (Syt)					
	7 =SH pressure transmitter temperature equivalence (tEu)	14 = çığırma noktası (SdP)					
AA2	Determination of temperature probe for AH2 and AL2 alarms control AA parameter		5	5	5	5	5
A0	Low and high temperature alarm difference		2.0	2.0	2.0	2.0	2.0
A1	Threshold type for AL and AH 1. Alarm delays		0	0	0	0	0
	0 = relative AL and AH set value 1 = absolute AL and AH absolute values						
A2	Threshold type for AL2 and AH2 2. Alarm delays		0	0	0	0	0
	0 = relative AL and AH set value 1 = absolute AL and AH finite values						
AL	Low temperature 1. alarm threshold		4	4	4	4	4
AH	High temperature 1. alarm threshold		5	5	5	5	5
AL2	Low temperature 2. alarm threshold		0	0	0	0	0
AH2	High Temperature 2. alarm threshold		0	0	0	0	0
Ad	Low and high temperature alarm alarm delay		15	15	15	15	15
A4	ID1 digital input configuration in S4 input		0	0	0	0	0
	0 = input is not active	5 = kapı switchi konfigürasyonu kompresör ve fanlar OFF					
	1 = momentary external alarm	6 = uzaktan ON/OFF					
	2 = delayed external alarm	7 = perde switchi					
	3 = defrost activation	8 = sürekli çevrim başlama / durma					
	4 = defrost starting	9 = ışık sensörü					

CAREL PARAMETERS		ISLAND FREEZER	WALL FREEZER	COMBI FREEZER	UPRIGHT FREEZER	COUNTER	MULTIDECK CABINET
A5	ID2 digital input configuration in S5 input, see the list in A4 parameter	0	0	0	0	0	0
A6	In the event of external alarm, solenoid/compressor working times. Compressor and solenoid work for this time, stop for 15 minutes and work againn.	0	0	0	0	0	0
	0 = Compressor/valve always OFF; 100 = compressor/valve always ON						
A7	Time delay for delayed external alarm	0	0	0	0	0	0
A8	Virtual digital input configuration see the list in A4 parameter	0	0	0	0	0	0
A09	Digital input selection transferred from master to slave		0	0	0	0	0
	0 = supervisor	3 = D13					
	1 = D11	4 = D14					
	2 = D12	5 = D15					
A10	ID3 digital input configuration in S6 input see the list in A4 parameter	0	0	0	0	0	0
A11	Id4 digital input configuration in S7 input, see the list in A4 parameter	0	0	0	0	0	0
A12	Digital input configuration in D15 input, see the list in A4 parameter	0	0	0	0	0	0
Ar	Is alarm signal in slaves shown in master?	1	1	1	1	1	1
	0 = no ; 1 = yes						
A13	When slaves are offline, hotgas bypass procedure	0	0	0	0	0	0
	0 = inactive 1 = active						
Fan (Evaporator fans)							
F0	Evaporator fan management	0	0	0	0	0	0
	0 = always ON						
	1 = Fan activation Sd defrost - Sv virtual (or Sd defrost - Sm blow double thermostat control) 2 =Activation Sd defrost probe						
F1	Fan activation threshold (only F0=1 and 2)	-5.0	-5.0	-5.0	-5.0	-5.0	-5.0
F2	Will fans stop when the compressor stops?	0	0	0	0	0	0
	0 =Fans work 1 = Fans stop						
F3	Status of fans during defrost	0	0	1	1	0	0
	0 = Fans work in Defrost 1 = fans stop						
Fd	Post-defrost drip fan waiting time	2	2	2	2	2	2
Frd	Fan activation difference (including variable speed fans)	2.0	2.0	2.0	2.0	2.0	2.0
F5	Evaporator fan stop threshold (difference 1C)	50.0	50.0	50.0	50.0	50.0	50.0
F6	Maximum Evaporator fan speed	100	100	100	100	100	100

CAREL PARAMETERS		ISLAND FREEZER	WALL FREEZER	COMBI FREEZER	UPRIGHT FREEZER	COUNTER	MULTIDECK CABINET
F7	Minimum Evaporator fan speed	0	0	0	0	0	0
F8	Evaporator fan peak time	0	0	0	0	0	0
	0 = Function inactive						
F9	PWM1/' fan control output selection (by phase-break)	1	1	1	1	1	1
	0 = pulse 1 = time-dependant						
F10	Time of working of evaporator fans at maximum speed	0	0	0	0	0	0
	0 = Function inactive						
Eud (Electronic valve)							
P1	Electronic valve	2	2	2	2	2	2
	0 = not used 1 = PWM valve 2 = CAREL E2V valve						
P3	Superheat Set point	10.0	10.0	10.0	10.0	10.0	10.0
P4	Proportional rate	15.0	15.0	15.0	15.0	15.0	15.0
P5	Integration rate (Integral factor)	150	150	150	150	150	150
	0 = Function inactive						
P6	Derivative rate	5.0	5.0	5.0	5.0	5.0	5.0
	0 = Function inactive						
P7	LowSH: low superheat threshold	7.0	7.0	7.0	7.0	7.0	7.0
P8	LowSH: low superheat integral time	15.0	15.0	15.0	15.0	15.0	15.0
	0 = Function inactive						
P9	LowSH: düşük superheat alarm gecikmesi	600	600	600	600	600	600
	0 = alarm inactive						
P10	Will solenoid valve be OFF in the event of low superheat or low suction temperature?	0	0	0	0	0	0
	1 = OFF is active						
P11	LSA: low evaporation temperature alarm	-45.0	-45.0	-45.0	-45.0	-45.0	-45.0
P12	LSA: alarm delay	600	600	600	600	600	600
	0 = alarm inactive						
P13	LSA: alarm difference (C)	10.0	10.0	10.0	10.0	10.0	10.0
	0 = reset the alarm all the time automatically						
P14	('blo') alarm signal activation	1	1	1	1	1	1
	1= blo alarm is active						
P15	Complementary temperature acceptance value in the event of Superheat pressure	-30	-30	-30	-12	-12	-12

CAREL PARAMETERS			ISLAND FREEZER	WALL FREEZER	COMBI FREEZER	UPRIGHT FREEZER	COUNTER	MULTIDECK CABINET
PH	Gas type		3	3	3	3	3	3
	1 = R22	8 = R600						
	2 = R134a	9 = R600a						
	3 = R404A	10 = R717						
	4 = R407C	11 = R744						
	5 = R410A	12 = R728						
	6 = R507A	13 = R1270						
	7 = R290	14 = R417A						
OSH	Superheat offset for modulation thermostate		0.0	0.0	0.0	0.0	0.0	0.0
	0 = Function inactive							
Phr	Fast updating of valve parameters by the supervisor		0	0	0	0	0	0
	0 = fast update is inactive							
PM1	MOP: Maximum evaporation pressure temperature value		50.0	50.0	50.0	50.0	50.0	50.0
PM2	MOP: Integral time		10.0	10.0	10.0	10.0	10.0	10.0
PM3	MOP: alarm delay		0	0	0	0	0	0
	0 = Function is inactive							
PM4	MOP: MOP function delay at the beginning		2	2	2	2	2	2
PM5	MOP: activating solenoid valve shutting		0	0	0	0	0	0
	0 = OFF is inactive							
	1 = OFF is active							
PL1	LOP: Minimum evaporation pressure temperature value		-50.0	-50.0	-50.0	-50.0	-50.0	-50.0
PL2	LOP: Integral time		0.0	0.0	0.0	0.0	0.0	0.0
PL3	LOP: alarm delay		0	0	0	0	0	0
	0 = Function is inactive							
SH	Superheat value		-	-	-	-	-	-
PPU	valve ON rate		-	-	-	-	-	-
tGS	Superheat temperature sensor reading value		-	-	-	-	-	-
tEu	Superheat pressure sensor temperature value (value of the pressure equivalent to the temperature)		-	-	-	-	-	-
/cE	Saturated evaporation temperature calibration		0.0	0.0	0.0	0.0	0.0	0.0
Po6	PWM expansion valve T on/OFF period		6	6	6	6	6	6
cP1	Valve position when the control is ON		30	30	30	30	30	30
Pdd	Post-Defrost valve position		10	10	10	10	10	10
PSb	valve standby position		0	0	0	0	0	0
PF	valve opening stages		-	-	-	-	-	-

CAREL PARAMETERS		ISLAND FREEZER	WALL FREEZER	COMBI FREEZER	UPRIGHT FREEZER	COUNTER	MULTIDECK CABINET	
PMP	Electronic expansion valve manual operation activation	0	0	0	0	0	0	
	0 = inactive 1 = active							
PMu	Manual valve position	-	-	-	-	-	-	
Phc	Large capacity valve activation	0	0	0	0	0	0	
Cnf (Configuration)								
In	MPXPRO Unit type	1	1	1	1	1	1	
	0 = Slave 1 = Master							
Sn	Number of slave in local network	0	0	0	0	0	0	
	0 = No Slave							
H0	Supervisor and Master-Slave network address	199	199	199	199	199	199	
H1	AUX1 output configuration	8	8	8	8	8	8	
	0 = no function							7 = second Evaporator defrost output
	1 = alarm without energy normally							8 = Evaporator Fan output
	2 = energy alarm normally							9 = Glass heater output
	3 = auxiliary output							10 = Suction valve
	4 = auxiliary output shared by Master with slaves							11 = Compensation valve
	5 = Light output							12 = Solenoid valve
6 = auxiliary output shared by Master with slaves								
H2	Button set and remote control deactivation	1	1	1	1	1	1	
	1 = Button set and remote control is active							
H3	Remote control activation code	0	0	0	0	0	0	
	0 =no remote control activation code							
H4	Buzzer activation	0	0	0	0	0	0	
	0 = active; 1 = inactive							
H5	Please see AUX2 output configuration H1 parameter	7	2	2	2	2	2	
H6	Terminal button set locking configuration	0	0	0	0	0	0	
H7	Please see AUX3 output configuration H1 parameter	5	5	5	5	5	5	
H8	Output association with time bands	0	0	0	0	0	0	
	0 = Light 1 = AUX							

CAREL PARAMETERS		ISLAND FREEZER	WALL FREEZER	COMBI FREEZER	UPRIGHT FREEZER	COUNTER	MULTIDECK CABINET
H9	Output association with AUX button	0	0	0	0	0	0
	0 = Light 1 = AUX						
H10	Compressor output configuration	0	0	0	0	0	0
	0 = Cooling 1 = heating						
H11	Fan output configuration	0	0	0	0	0	0
	0 = Cooling 1 = Heating						
H12	Light sensor threshold	25	25	25	25	25	25
H13	Please see AUX4 output configuration H1 parameter	12	12	12	12	12	12
Hdn	default set parameters number	0	0	0	0	0	0
Htc	External time card insertion	0	0	0	0	0	0
	0 = not inserted						
rHu	Manual glass heater activation rate (rHt period)	70	70	70	70	70	70
	0 = Function is inactive						
rHt	Manual glass heater activation period	5	5	5	5	5	5
	0 = Function is inactive						
rHo	Glass heater modulation offset	2.0	2.0	2.0	2.0	2.0	2.0
rHd	Glass heater modulation difference	0.0	0.0	0.0	0.0	0.0	0.0
rHL	PWM output load type for glass heater modulation	0	0	0	0	0	0
	0 = resistant 1 = inductive						
rHA	Factor A for calculated glass temperature	2	2	2	2	2	2
rHb	Factor B for calculated glass temperature	22	22	22	22	22	22
HSt (Alarm log)							
HSo to 9	0 dan 9'a alarmlar (sete basın)	-	-	-	-	-	-
---	0 dan 9'a alarm kodu	-	-	-	-	-	-
h_	0 dan 9'a alarm houri	0	0	0	0	0	0
n_	0 dan 9'a alarm minutesi	0	0	0	0	0	0
---	0 dan 9'a alarm süresi	0	0	0	0	0	0
HcP (HACCP alarms)							
Ht0	HACCP alarm	0	0	0	0	0	0
HAn	HA alarm type number	0	0	0	0	0	0

CAREL PARAMETERS		ISLAND FREEZER	WALL FREEZER	COMBI FREEZER	UPRIGHT FREEZER	COUNTER	MULTIDECK CABINET
HA to HA2	HA type active HACCP alarm number	-	-	-	-	-	-
y_	From 1 to 3 alarm-Year	0	0	0	0	0	0
M_	From 1 to 3 alarm - month	0	0	0	0	0	0
d_	From 1 to 3 alarm - which day of the month	0	0	0	0	0	0
h_	From 1 to 3 alarm - hour	0	0	0	0	0	0
n_	From 1 to 3 alarm - minute	0	0	0	0	0	0
...	From 1 to 3 alarm - Alarm time	0	0	0	0	0	0
HFn	HF alarm type number	0	0	0	0	0	0
HF to HF2	HF type active HACCP alarm number	-	-	-	-	-	-
y_	From 1 to 3 alarm - Year	0	0	0	0	0	0
M_	From 1 to 3 alarm -month	0	0	0	0	0	0
d_	From 1 to 3 alarm - which day of the month	0	0	0	0	0	0
h_	From 1 to 3 alarm - hour	0	0	0	0	0	0
n_	From 1 to 3 alarm - minute	0	0	0	0	0	0
_	From 1 to 3 alarm - Alarm time	0	0	0	0	0	0
Htd	HACCP alarm delay	0	0	0	0	0	0
	0 = alarm viewing deactivated						
rtc (Real Time Clock)							
td1 to 8	Defrost time from 1 to 8 (press Set)	-	-	-	-	-	-
d_	From 1 to 8 defrost day selection	0	0	0	0	0	0
	0 = no defrost						
	1 to 7 = days one by one from Monday to Sunday						
	8 = every day from Monday to Friday						
	9 = everyday from Monday to Saturday						
	10 = only Saturday Sunday						
11 = everyday							
h_	Defrost hour	0	0	0	0	0	0
n_	Defrost minute	0	0	0	0	0	0
P_	Power defrost selection	0	0	0	0	0	0
	0 = Normal defrost; 1 =Power defrost						
tS1 to 8	Time band starting from 1 to 8 (press Set)	-	-	-	-	-	-
d	Time band starting: day	0	0	0	0	0	0
h	Time band starting: hour	0	0	0	0	0	0
n	Time band starting: minute	0	0	0	0	0	0
tE1 to 8	Time band end from 1 to 8 (press Set)	-	-	-	-	-	-

DANFOSS PARAMETERS		ISLAND FREEZER	WALL FREEZER	COMBI FREEZER	UPRIGHT FREEZER	COUNTER	MULTIDECK CABINET
Normal operation							
---	Temperature (setpoint)	-26	-20	-20	-20	0	2
Thermostat							
r01	Differential	2	2	2	2	2	2
r02	Max. limitation of setpoint setting	-22	-18	-18	-18	-4	-4
r03	Min. limitation of setpoint setting	-29	-23	-23	-23	4	4
r04	Adjustment of temperature indication	0	0	0	0	0	0
r05	Temperature unit (°C/°F)	0	0	0	0	0	0
r09	Correction of the signal from S4	0	0	0	0	0	0
r10	Correction of the signal from S3	0	0	0	0	0	0
r12	Manual service, stop regulation, start regulation (-1, 0, 1)	1	1	1	1	1	1
r13	Displacement of reference during night operation	0	0	0	0	0	0
r14	Define thermostat function	1	1	1	1	1	1
	1=ON/OFF						
	2=Modulating						
r15	Definition and weighting, if applicable, of thermostat sensors - S4% (100%=S4, 0%=S3)	100	0	0	0	50	50
r16	Time between melt periods	0	0	0	0	0	0
r17	Duration of melt periods	0	0	0	0	0	0
r21	Temperature setting for thermostat band 2 . As differential use r01	-26	-20	-20	-22	0	0
r59	Correction of the signal from S6	0	0	0	0	0	0
r61	Definition and weighting, if applicable, of thermostat sensors when night cover is on. (100%=S4, 0%=S3)	100	0	0	0	50	50
r62	Heat function	2	2	2	2	2	2
	Neutral zone between refrigeration and heat function						
r63	Time delay at switch between refrigeration and heat function	0	0	0	0	0	0
Alarms							
A03	Delay for temperature alarm	15	15	15	15	20	20
A04	Delay for door alarm	0	0	0	0	0	0
A12	Delay for temperature alarm after defrost	60	60	60	60	60	60
A13	High alarm limit for thermostat 1	-18	-15	-15	-15	4	6
A14	Low alarm limit for thermostat 1	-30	-26	-26	-26	-6	-6
A20	High alarm limit for thermostat 2	-18	-15	-15	-15	4	6
A21	Low alarm limit for thermostat 2	-30	-26	-26	-26	-6	-6
A22	High alarm limit for sensor S6 at thermostat 1	8	8	8	8	8	8
A23	Low alarm limit for sensor S6 at thermostat 1	-30	-30	-30	-30	-30	-30
A24	High alarm limit for sensor S6 at thermostat 2	8	8	8	8	8	8
A25	Low alarm limit for sensor S6 at thermostat 2	-30	-30	-30	-30	-30	-30

DANFOSS PARAMETERS		ISLAND FREEZER	WALL FREEZER	COMBI FREEZER	UPRIGHT FREEZER	COUNTER	MULTIDECK CABINET
A26	S6 alarm time delay	240	240	240	240	240	240
	With setting = 240 the S6 alarm will be omitted						
A27	Alarm time delay or signal on the DI1 input	30	30	30	30	30	30
A28	Alarm time delay or signal on the DI2 input	30	30	30	30	30	30
A36	Signal for alarm thermostat. S4% (100%=S4, 0%=S3)	100	0	0	0	50	50
A52	Delay for S6 (product sensor alarm) after defrost	90	90	90	90	90	90
Compressor							
c01	Min. ON-time	0	0	0	0	0	0
c02	Min. OFF-time	0	0	0	0	0	0
c05	Time delay for cutin of comp.2	5	5	5	5	5	5
Defrost							
d01	Defrost method	1	1	1	1	1	1
	0=off						
	1= EL						
	2= gAs						
d02	Defrost stop temperature	10	10	12	12	10	10
d03	Interval between defrost starts	8	8	6	6	6	6
d04	Max. defrost duration	35	35	35	35	45	45
d05	Displacement of time on cutin of defrost at start-up	0	0	0	0	0	0
d06	Drip off time	2	2	2	2	3	3
d07	Delay for fan start after defrost	2	2	2	2	0	0
d08	Fan start temperature	-5	-5	-5	-5	-5	-5
d09	Fan cutin during defrost	1	1	0	0	1	1
	0: Stopped						
	1: Running						
	2: Running during pump down and defrost						
d10	Defrost sensor	3	1	1	1	1	1
	0 =Stop on time						
	1=S5						
	2=S4						
	3=Sx						
(Application 1-8 and 10: both S5 and S6. Application 9: S5 and S5B)							
d16	Pump down delay	0	0	0	0	0	0
d17	Drain delay (used at hot gas defrost only)	0	0	0	0	0	0
d18	Max. aggregate refrigeration time between two defrosts	0	0	0	0	0	0
d20	Heat in drip tray. Time from defrosting stops to heating in the drip tray is switched off	30	30	30	30	30	30

DANFOSS PARAMETERS		ISLAND FREEZER	WALL FREEZER	COMBI FREEZER	UPRIGHT FREEZER	COUNTER	MULTIDECK CABINET	
t45	Clock - Setting of date	REAL TIME	REAL TIME	REAL TIME	REAL TIME	REAL TIME	REAL TIME	
t46	Clock - Setting of month	REAL TIME	REAL TIME	REAL TIME	REAL TIME	REAL TIME	REAL TIME	
t47	Clock - Setting of year	REAL TIME	REAL TIME	REAL TIME	REAL TIME	REAL TIME	REAL TIME	
Miscellaneous								
o01	Delay of output signals after start-up	5	5	5	5	5	5	
o02	Input signal on DI1. Function:	0	0	0	0	0	0	
	0=not used							7=thermostat band changeover (activate r21)
	1=status on DI1							8=alarm function when closed
	2=door function with alarm when open							9=alarm function when open
	3=door alarm when open							10=Appliance cleaning (pulse signal)
	4=defrost start (pulse-signal)							11=forced cooling at hot gas defrost
	5=ext.main switch							12=night cover
6=night operation	15=case shut down							
o03	Network address	0	0	0	0	0	0	
o04	On/Off switch (Service Pin message) IMPORTANT! o61 must be set prior to o04 (used at LON 485 and DANBUSS only)	Off	Off	Off	Off	Off	Off	
o05	Access code 1 (all settings)	0	0	0	0	0	0	
o06	Used sensor type	0	0	0	0	0	0	
	0=Pt1000							
	1=Ptc1000,							
o08	Readout of software version	**	**	**	**	**	**	
o16	Max hold time after coordinated defrost	20	20	20	20	20	20	
o17	Select signal for display view. S4% (100%=S4, 0%=S3)	100	0	0	0	50	50	
o20	Pressure transmitter working range – min. value	-1	-1	-1	-1	-1	-1	
o21	Pressure transmitter working range – max. value	12	12	12	12	12	12	

DANFOSS PARAMETERS			ISLAND FREEZER	WALL FREEZER	COMBI FREEZER	UPRIGHT FREEZER	COUNTER	MULTIDECK CABINET	
o30	Refrigerant setting:		19	19	19	19	19	19	
	1=R12	15=R227							29=R1270
	2=R22	16=R401A							30=R417A
	3=R134a	17=R507							31=R422A
	4=R502	18=R402A							32=R413A
	5=R717	19=R404A							33=R422D
	6=R13	20=R407C							34=R427A
	7=R13b1	21=R407A							35=R438A
	8=R23	22=R407							36=R513A
	9=R500	23=R410A							37=R407F
	10=R503	24=R170							38=R1234ze
	11=R11	25=R290							39=R1234yf
	12=R142b	26=R600							40=R448A
	13=User defined	27=R600a							41=R449A
14=R32	28=R744	42=R452A							
o30	Refrigerant setting:		19	19	19	19	19	19	
o37	Input signal on DI2. Function:		0	0	0	0	0	0	
	(0=not used.	5=ext. main switch							10=Appliance cleaning (pulse signal).
	1=status on DI2.	6=night operation							11=forced cooling at hot gas defrost.).
	2=door function with alarm when open.	7=thermostat band changeover (activate r21).							12=night cover,
	3=door alarm when open.	8=alarm function when closed.							13=coordinated defrost).
4=defrost start (pulse-signal).	9=alarm function when open.	15=case shut down							
o38	Configuration of light function:		1	1	1	1	1	1	
	1=Light follows day /night operation,								
	2=Light control via data communication via 'o39',								
	3=Light control with a DI-input,								
4=As "2", but light switch on and night cover will open if the network cut out for more than 15 minutes.									
o39	Activation of light relay (only if o38=2) On=light		Off	Off	Off	Off	Off	Off	
o41	Rail heat On time during day operations		100	100	100	100	100	100	
o42	Rail heat On time during night operations		100	100	100	100	100	100	
o43	Rail heat period time (On time + Off time)		10	10	10	10	10	10	
o46	Appliance cleaning.		0	0	0	0	0	0	
	0=no Appliance cleaning.								
	1=Fans only.								
	2=All output Off.								
o61	Selection of EL diagram. See overview page 12 and 13		9	1	4	4	1	1	
o62	Download a set of predetermined settings. See overview page 27.		0	0	0	0	0	0	

DANFOSS PARAMETERS			ISLAND FREEZER	WALL FREEZER	COMBI FREEZER	UPRIGHT FREEZER	COUNTER	MULTIDECK CABINET	
o64	Access code 2 (partial access)		0	0	0	0	0	0	
o67	Replace the controllers factory settings with the present settings		Off	Off	Off	Off	Off	Off	
o84	Input signal on DI3. Function: (high voltage input)		0	0	0	0	0	0	
	(0=not used.	6=night operation,							12=night cover.
	1=status on DI2.	7=thermostat band changeover (activate r21)							13=Not used.
	2=door function with alarm when open.	8=Not used.							14=Refrigeration stopped (forced closing)).
	3=door alarm when open	9=Not used.							15=case shut down
	4=defrost start (pulse-signal).	10=Appliance cleaning (pulse signal).							
	5=ext. main switch	11=forced cooling at hot gas defrost,							
o85	Rail heat control		0	0	0	0	0	0	
	0=not used,								
	1=pulse control with timer function (o41 and o42),								
	2=pulse control with dew point function								
o86	Dew point value where the rail heat is minimum		8	8	8	8	8	8	
o87	Dew point value where the rail heat is 100% on		17	17	17	17	17	17	
o88	Lowest permitted rail heat effect in %		30	30	30	30	30	30	
o89	Time delay from "open door" refrigeration is started		30	30	30	30	30	30	
o90	Fan operation at stopped cooling (forced closing): 0= Stopped (defrost allowed)		1	1	1	1	1	1	
	1= Running (defrost allowed)								
	2= Stopped (defrost not allowed)								
	3= Running (defrost not allowed)								
o92	1=defrost stop temperature,		1	1	1	1	1	1	
	2=S6 temperature,								
	3=S5_B temperature (application 9), 4=S3B (application 10)								
o97	Display of temperature		1	1	1	1	1	1	
	1= u56 Air temperature								
	2= u36 product temperature								
o98	Light and night blinds defined		0	0	0	0	0	0	
	0: Light is switch off and night blind is open when the main switch is off								
	1: Light and night blind is independent of main switch								

DANFOSS PARAMETERS		ISLAND FREEZER	WALL FREEZER	COMBI FREEZER	UPRIGHT FREEZER	COUNTER	MULTIDECK CABINET
P41	Configuration of alarm relay	1	1	1	1	1	1
	The alarm relay will be activated upon an alarm signal from the following groups:						
	1 - High temperature alarms						
	2 - Low temperature alarms						
	4 - Sensor error						
	8 - Digital input enabled for alarm 16 - Defrosting alarms						
	32 - Miscellaneous 64 - Injection alarms						
The groups that are to activate the alarm relay must be set by using a numerical value which is the sum of the groups that must be activated. (E.g.: a value of 5 will activate all high temperature alarms and all sensor error and 0 will cancel the relay function).							